

RESTAURANT RANGES

CHALLENGER XL GAS RESTAURANT RANGE

6 OPEN BURNERS / 24" FRY TOP

60" WIDE GAS RANGE



Model C60-SC-6B-24G-N
(Shown with optional casters)

SPECIFICATIONS

60" wide gas restaurant range, Wolf Model No. C60-SC-6B-24G-N. Fully MIG welded aluminized steel frame for added durability. Stainless steel front, sides, backriser, highshelf and 6" adjustable legs. Extra deep crumb tray with welded corners. Six 30,000 BTU/hr. cast burners with lift-off burner heads. Energy saving flashtube open burner ignition system (one pilot for every two burners) shrouded for reliability. Heavy duty cast grates, easy lift-off 12" x 12½" in the front and 12" x 14½" in the back to better accommodate stock pots or large pans. Grates have a built in aeration bowl for greater efficiency. 24" manual fry top, 7/8" thick with 4" wide front grease trough. Burner knobs are cool to the touch, high temperature material. Two standard bakers depth ovens: each oven is 25,000 BTU/hr. with porcelain oven bottom and door panel, measures 27"d x 26¾"w x 14"h. Oven thermostat adjusts from 250°F to 500°F with a low setting. Each oven is supplied with two racks, two rack guide sets, and four rack positions. Oven doors are heavy duty with an integrated door hinge/spring mechanism requiring no adjustment. 1" rear gas connection and pressure regulator. Total input 270,000 BTU/hr.

Exterior Dimensions:

34¾"d x 60"w x 58"h on 6" adjustable legs.

- C60-SC-6B-24G-N** 1 Standard Oven / 1 Convection Oven / Natural Gas
- C60-SC-6B-24G-P** 1 Standard Oven / 1 Convection Oven / Propane
- C60-CC-6B-24G-N** 2 Convection Ovens / Natural Gas
- C60-CC-6B-24G-P** 2 Convection Ovens / Propane

STANDARD FEATURES

- Fully MIG welded frame.
- Stainless steel front, sides, backriser, lift-off high shelf.
- 6" Stainless steel adjustable legs.
- 30,000 BTU/hr. open top burners with lift-off heads.
- Shrouded flash tube pilot system (one pilot per two burners).
- Heavy duty cast grates, easy lift-off 12" x 12½" in front and 12" x 14½" in the rear.
- Manual fry top, 7/8" thick with 4" wide front grease trough.
- Extra deep pull out crumb tray with welded corners.
- Two 25,000 BTU/hr. baker's depth standard ovens, full size sheet pans fit side-to-side or front-to-back.
- Oven thermostat adjusts from 250°F to 500°F.
- Two oven racks and four rack positions.
- 25,000 BTU/hr. Snorkler convection oven in place of std. oven 24"d x 26¾"w x 13¾"h (115v - 1 phase blower motor 4 amp, 6' cord and plug), includes three oven racks. Full size sheet pans fit side-to-side.
- One year limited parts and labor warranty.

OPTIONS (Factory Installed)

- Thermostatically controlled (snap-action) on 24" and 36" only.

ACCESSORIES (Packaged & Sold Separately)

- Extra oven rack with rack guides.
- Casters (set of four).
- Flanged feet (set of four).
- Reinforced high shelf for mounting salamander broiler.
- 10" stainless steel stub back.

CHALLENGER XL GAS RESTAURANT RANGE

6 OPEN BURNERS / 24" FRY TOP

60" WIDE GAS RANGE

INSTALLATION INSTRUCTIONS

1. A pressure regulator sized for this unit is included. Natural gas 5.0" W.C., propane gas 10.0" W.C.
2. Gas line connecting to range must be 1" or larger. If flexible connectors are used, the inside diameter must be 1" or larger.
3. An adequate ventilation system is required for commercial cooking equipment. Information may be obtained by writing to the National Fire Protection Association, 1 Batterymarch Park, Quincy, MA 02269, www.NFPA.org. When writing, refer to NFPA No. 96.
4. These units are manufactured for installation in accordance with ANSZ223.1A (latest edition), National Fuel Gas Code. Copies may be obtained from The American Gas Association, 400 N Capitol St. NW, Washington, DC 20001, www.AGA.org.

5. **Clearances**

	Rear	Sides
Combustible	6"	10"
Standard Oven Non-combustible	0"	0"
Convection Oven Non-combustible	Min. 4"	0"
6. For proper combustion, install equipment on adjustable legs or casters provided with unit.

NOTE: In line with its policy to continually improve its product, Wolf Range Company reserves the right to change materials and specifications without notice.

Specify type of gas when ordering.
Specify altitude when above 2,000 feet.

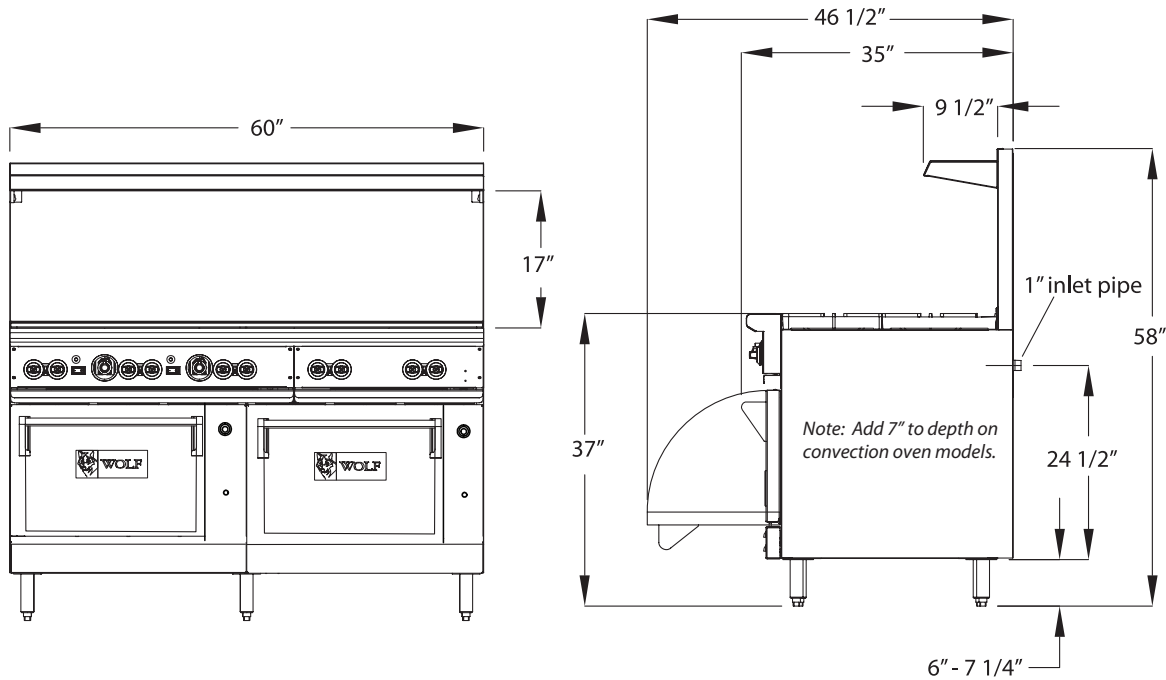

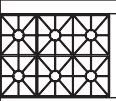
TOP CONFIGURATION	MODEL NUMBER	DESCRIPTION	TOTAL INPUT BTU / HR	SHIPPING WEIGHT LBS / KG
	C60-SC-6B-24G-N	1 Standard Oven / 1 Convection Oven / 6-Burners / 24" Fry Top Natural Gas	270,000	1,050 / 476
	C60-SC-6B-24G-P	1 Standard Oven / 1 Convection Oven / 6-Burners / 24" Fry Top Propane	270,000	1,050 / 476
	C60-CC-6B-24G-N	2 Convection Ovens / 6-Burners / 24" Fry Top / Natural Gas	270,000	1,110 / 503
	C60-CC-6B-24G-P	2 Convection Ovens / 6-Burners / 24" Fry Top / Propane	270,000	1,110 / 503

This appliance is manufactured for commercial use only and is not intended for home use.