



# DOUBLE SECTION FULL FEATURED GAS CONVECTION OVEN

**WOLF RANGE COMPANY**

**MODEL: WLGO2 Double Section Gas Convection Oven**



Model WLGO2



CSA design certified.  
NSF listed.

Approved by \_\_\_\_\_

Date: \_\_\_\_\_

**SPECIFY TYPE OF GAS WHEN ORDERING.  
SPECIFY ALTITUDE WHEN ABOVE 2,000 FT.**

**BASIC MODEL:**

WLGO2 Double section gas convection oven

**KEY FEATURES:**

- ▶ Stainless steel front and legs.
- ▶ Aluminized sides and top.
- ▶ Stainless steel doors with double pane windows.
- ▶ 44,000 BTU/hr. burner per section.
- ▶ Electronic spark igniters.
- ▶ 1/2 H.P. two speed oven blower-motors. 120/60/1 with 6' cord and plug. 9 amps per section. 18 amps total draw.
- ▶ Solid state temperature controls adjust from 150° to 500°F. 60 minute timers with audible alarm.
- ▶ Oven cool switch for rapid cool down.
- ▶ Porcelain enamel on steel oven interior.
- ▶ Five nickel plated oven racks with eleven rack positions per section.
- ▶ 3/4" rear gas connection with gas pressure regulator and safety solenoid system.
- ▶ One year limited parts and labor warranty.

**OPTIONAL FEATURES:**

- ▷ Casters.

**ACCESSORIES**

- ▷ Extra oven rack(s).
- ▷ Stainless steel drip pan.
- ▷ Flexible gas hose with quick disconnect and restraining device.

**SPECIFICATIONS:**

Double section gas convection oven, Wolf Model No. WLGO2. Stainless steel front and legs. Aluminized sides and top. Independently operated stainless steel doors with double pane windows. Non-sag insulation applied to the top, rear, sides, bottom and doors. Porcelain enamel on steel oven interiors measure 29"w x 22 1/8"d x 20"h. Two interior oven lights per section. Five nickel plated oven racks per section measure 28 1/4" x 20 1/2". Eleven position nickel plated rack guides with positive rack stops. One 44,000 BTU/hr. burner per section, 88,000 total BTU/hr. Electronic spark igniters. Furnished with a two speed 1/2 H.P. oven blower-motor per section. Solid state temperature controls adjust from 150° to 500°F. 60 minute timers with audible alarm. Oven cool switch for rapid cool down. 120 volt, 60 Hz, 1 ph power supply required. 6' cord and plug. 9 amps per section. 18 amps total draw.

Exterior dimensions: 40"w x 42 1/4"d x 70"h on 8" legs. Depth measurement includes door handles.

**WOLF RANGE COMPANY**

Wolf Range Company  
Division of ITW Food Equipment Group LLC  
(800) 366-9653  
www.wolfrange.com



# Model WLGO2 Double Section Full Featured Gas Convection Oven

## IMPORTANT

1. A gas pressure regulator is supplied for this unit. Natural gas 3.5" W.C., propane gas 10.0" W.C.
2. An adequate ventilation system is required for commercial cooking equipment. Information may be obtained by writing to the National Fire Protection Association, 1 Batterymarch Park, Quincy, MA 02269, www.NFPA.org. When writing, refer to NFPA No. 96.
3. National Electrical Code, ANSI/NFPA-70 (latest edition). Copies may be obtained from the National Fire Protection Association, 1 Batterymarch Park, Quincy, MA 02269-7471.
4. These units are manufactured for installation in accordance with ANSZ223.1 (latest edition), National Fuel Gas Code. Copies may be obtained from American Gas Association Inc., Accredited Standards Committee Z223, 400 N. Capitol St. NW, Washington, DC 20001 or the Secretary Standards Council, NFPA, 1 Batterymarch Park, Quincy, MA 02169-7471.
5. Clearances:
 

	Combustible	Non-combustible
Rear	2"	2"
Right Side	4"	4"
Left Side	1"	0"
6. This appliance is manufactured for commercial installation only and is not intended for home use.

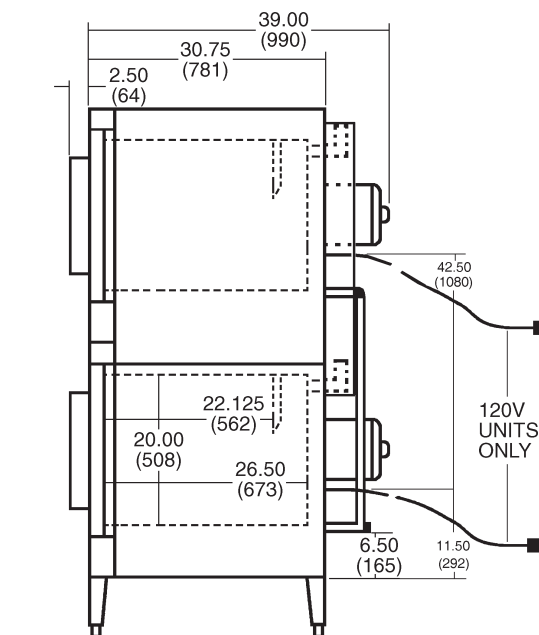
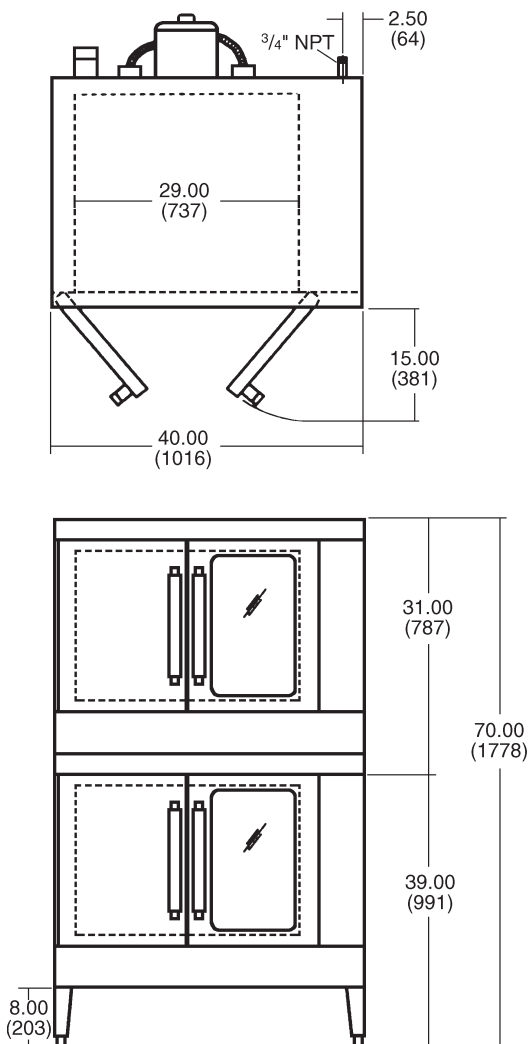

MODEL NO.	WIDTH	DEPTH (INCLUDES HANDLES)	HEIGHT	BTU/HR. PER OVEN	TOTAL BTU/HR.	ELECTRICAL	APPROX. SHP. WT.	
							LBS.	KG
WLGO2	40"	42 1/4"	70"	44,000	88,000	120/60/1	994	450

**NOTE:** In line with its policy to continually improve its product, Wolf Range Company reserves the right to change materials and specifications without notice.  
 This appliance is manufactured for commercial use only and is not intended for home use.