

Crimsco Inc. Correctional Meal Delivery Specialists



IMC-COR-48

IMC-COR Series Insulated tray delivery carts

These rugged, built to last delivery carts are fully welded and are designed for secure, fast meal delivery service.

These carts are not just some restaurant style cart with security features attached. Our carts are manufactured from the ground up specifically for the correctional field.

Our reinforced fully welded base and integral Dual layer fully welded corner post design insures the elimination of any cabinet torque during transport.

The bottom line is, your environment is tough! Our standards are even tougher!

Crimsco is corrections

Model IMC-COR Series Holding and Transport Cabinet FOR INSULATED TRAYS

Standard Features

- ▼ 12 gauge Lockable transport latch
- ▼ Tamper proof fasteners throughout
- ▼ Flush recessed door pull
- ▼ Heavy duty 8" casters
- ▼ Magnetic door closure
- ▼ All stainless steel
- ▼ Fully welded
- ▼ Integral dual layer fully welded corner posts
- ▼ Super duty reinforced base
- ▼ Center hinged Doors
- ▼ Full perimeter bumper
- ▼ One year parts and labor warranty
- ▼ Fully welded 12 gauge hinges

- ▼ Accepts 48 or 72 insulated stackable trays
maximum tray size = 14" x 18" x 2.75"

Options

- ▼ Heavy Duty Shelves (1 per side)
- ▼ Semi pneumatic Casters
- ▼ 3 sided top rail
- ▼ Side mounted beverage holder

Crimsco a Division of *ITW* FEG

7737 N 81st Street ▼ Milwaukee, WI 53223 USA
414-702-8972 ▼ 800-367-8413 ▼ Fax 414-354-2821

Crimsco Inc. Correctional Meal Delivery Specialists



Model IMC-COR Series For insulated trays

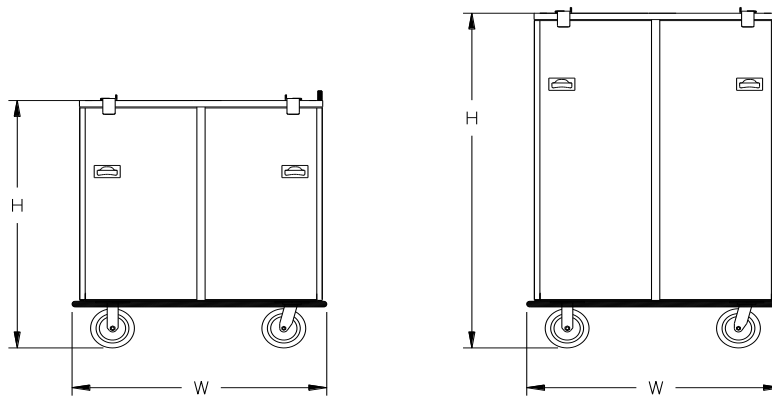

Model	Capacity	Width	Depth	Height	Weight	Electrical	NEMA	Casters
IMC-COR-48	48 insulated trays (stacked)	48"	32.25"	50.50"	350lb	N/A	N/A	8"
IMC-COR-72	72 insulated trays (stacked)	48"	32.25"	62.50"	450lbs	N/A	N/A	8"

SPECIFICATIONS

Construction: Heliarc welded, stainless steel double pan construction. Support channels welded at base, integral dual layer fully welded corner posts, 1.5" support tubes fully welded at front and back of cart.

Bumper: Continuous wrap around aluminum (dove-tail) designed bumper complete with (secure fit) non-marking vinyl insert.

Doors: Double pan design, fully insulated, Center hinged, 12 gauge hinges, recessed door pulls

Casters: 8" super duty polyurethane casters mounted to 1/4 inch mounting plates. (2) swivel with brakes (2) rigid. Casters equipped with mounting plate shall be secured to reinforced base channel with 3/8" carriage bolts.

Security Detail: All fasteners shall be tamper proof, hinges and transport latches are 12 gauge And fully welded.

Tray configuration: (IMC-COR-48)= 2 stacks of 12 trays with a 13th as a lid behind each door for a total of (48) (IMC-COR-72)= 2 stacks of 18 trays with a 19th as a lid behind each door for a total of (72)

Note: in line with its policy to continually improve its products, Crimsco Inc. reserves the right to change materials and specifications without notice.

Crimsco a Division of *ITW* FEG
7737 N 81st Street ▼ Milwaukee, WI 53223 USA
414-702-8972 ▼ 800-367-8413 ▼ Fax 414-354-2821