

## MODEL 1826-7-DBL-IS

### Holding & Transport Cabinets



UL Listed to Canadian safety standards  
Classified by UL to NSF Std. #4

## Specifications

Wittco Model 1826-7-DBL-IS heated holding and transport cabinets feature 2 separately controlled compartments in 2 separate cabinets, one stacked on top of the other. Complete with 5" heavy duty casters (2 swivel with brakes and 2 rigid). Each compartment has a recessed control panel containing dual indicator light, thermometer, and full range thermostat for temperatures up to 190°F (88°C). Individual compartment capacity is 7 each 18" x 26" sheet pans, 14 each 12" x 20" x 2½" steam table pans, or a combination of both on 3" centers. Each compartment comes with 5 pairs of universal tray slides adjustable on 1½" centers. Cabinet interior and exterior are both constructed out of 20 gauge stainless steel. Recessed side-mounted push/pull handles, magnetic action door latch, and full insulation; 1½" in side walls and 2" in top. Integrated steel frame for maximum strength. Lifetime warranty on heating elements. Complete with 2 cords and 2 plugs: NEMA 5-15 for 120 volts and NEMA 6-15 for 208-240 volts. 120 Volts, 1,000 Watts, 8.3 Amps per compartment

## Standard Features

- Holding and Transport Cabinet with 2 separately controlled compartments in 2 separate cabinets, one stacked on top of the other
- Capacity per compartment
  - 7 each 18" x 26" sheet pans
  - 14 each 12" x 20" x 2½" pans
  - Or a combination of both on 3" centers
- 5" Heavy duty casters (2 with swivel with brakes and 2 rigid)
- Recessed side mounted push/pull handles
- Two (2) recessed control panels
- Two (2) dual indicator
- Two (2) thermometers
- Two (2) full range thermostats for temperatures up to 190°F (88°C)
- 5 Pairs of universal tray slides adjustable on 1½" centers per compartment
- Interior and exterior are both constructed out of 20 gauge stainless steel
- Fully insulated with 1½" in side walls and 2" in top
- Integrated steel frame for maximum strength
- Magnetic action door latches
- Lifetime warranty on heating elements
- Complete with 2 cords and 2 plugs: NEMA 5-15 for 120 volts and NEMA 6-15 for 208-240 volts
- 120 Volts, 1,000 Watts, 8.3 Amps per compartment

## Options

- Left hand hinged door
- Additional universal tray slides
- Humidity pan
- Full perimeter bumper
- Cord wrap
- Glass Doors

Approved by: \_\_\_\_\_

Date: \_\_\_\_\_



FOODSERVICE EQUIPMENT

# MODEL 1826-7-DBL-IS

Holding & Transport Cabinets

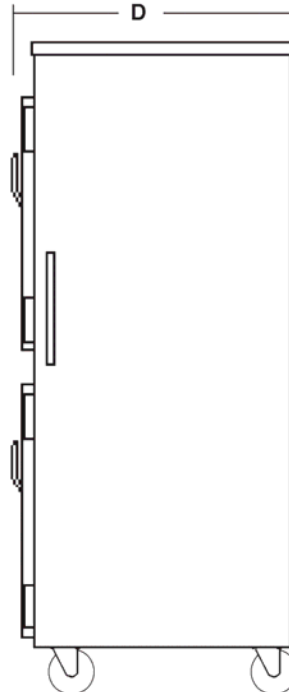
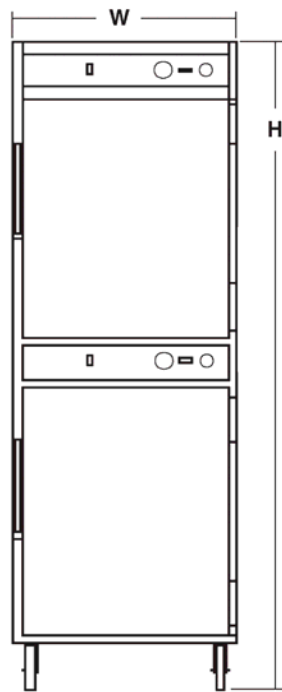
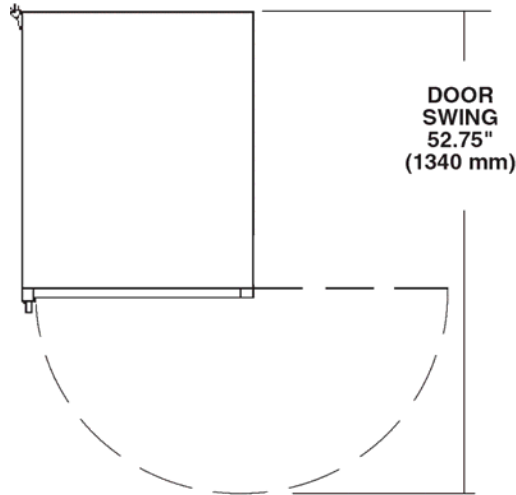

Holding & Transport Cabinets Model 1826-7-DBL-IS

Model No	Capacity Per Compartment 12 "x20 "x2½ "	Capacity Per Compartment 18 "x26 "	High	Wide	Deep	Shipping Weight	Volts Per Compartment	Watts Per Compartment	Amps Per Compartment
1826-7-DBL-IS	14	7	73.75 " 1852mm	24.75 " 629mm	31.75 " 807mm	342# 155kg	120	1000	8.3

Note: In line with its policy to continually improve its products, Wittco Foodservice Equipment reserves the right to change materials and specifications without notice.

Wittco Foodservice Equipment 7737 N 81st Street Milwaukee, WI 53223 USA

414-354-3080 800-367-8413 FAX 414-354-2821

