

MODELS 200-1-SL-LP and 200-2-SL-LP

Slim-Line Low-Profile Drawer Warmers



Model 200-2-SL-LP



UL Listed to Canadian safety standards
Classified by UL to NSF Std. #4

Specifications

Wittco Models 200-1-SL-LP and 200-2-SL-LP (Slim-Line Low-Profile) one and two drawer heated drawer warmers are provided with a 12 " x 20" x 6 " steam table pan for each drawer. Recessed control panel containing dual indicator light and full range thermostat for temperatures up to 190°F (88°C), and individual elements and thermometer for each drawer. Heavy duty 14 gauge stainless steel drawer slides and stainless steel roller bearings provide for smooth dependable operation of the drawers. Each self-closing drawer comes with a moist/crisp vent control and the oversize drawer handle is welded to the drawer front for increased durability. Drawer slides and elements carry a lifetime replacement warranty. Fully insulated with 1 "in the side walls and top. Cabinet interior and exterior are both constructed out of 20 gauge stainless steel. Each unit comes complete with 5 " adjustable legs and a 6 foot cord and NEMA 5-15 plug (6-15 plug for 208/240 volt units). 120 volts, 600 watts, 5 amps per drawer.

Standard Features

- Heavy duty drawer slim-line low-profile heated drawer warmers standard with a 12 " x 20 " x 6 " steam table pan for each drawer
- Each self-closing drawer has
 - A recessed control panel
 - A full range thermostat for temperatures up to 190°F (88°C)
 - A dual indicator light
 - Individual elements
 - A thermometer
 - A welded on oversize handle for increased durability and easy operation
 - A moist/crisp vent control
 - 14 gauge stainless steel drawer slides and stainless steel roller bearings provide for smooth dependable operation of the drawers.
- Interior and exterior are both constructed out of 20 gauge stainless steel.
- Fully insulated with 1 "in the side walls and top
- A life time warranty on
 - Elements
 - Drawer slides
- Adjustable 5" legs
- Complete with 6 foot cord and plug: NEMA 5-15 plug (6-15 plug for 208/240 volt units)
- 120 volts, 600 watts, 5 amps per drawer

Options

- 208/240 volts
- Trim kit for built-in applications
- Caster kits

Approved by: _____

Date: _____

MODELS 200-1-SL-LP and 200-2-SL-LP

Slim-Line Low-Profile Drawer Warmers

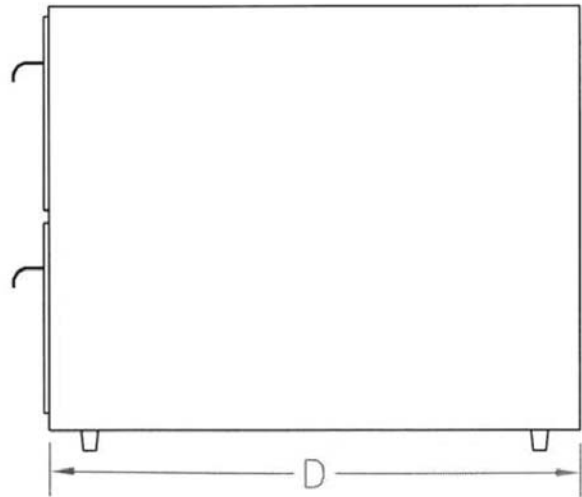
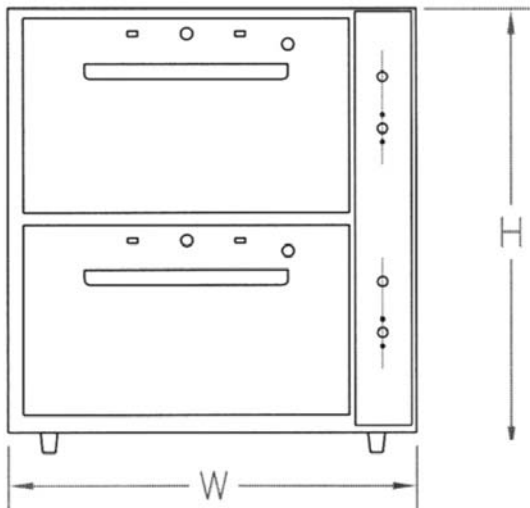
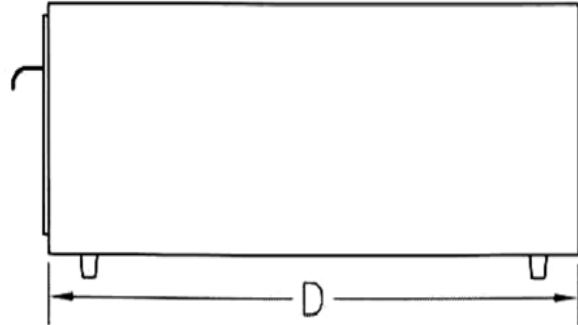
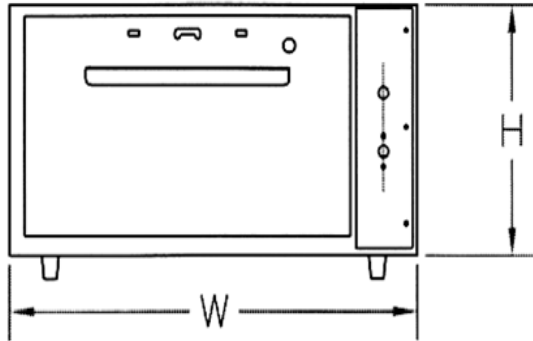

Model No	Capacity Per Drawer	High	Wide	Deep	Shipping Weight	Volts	Watts	Amps
200-1-SL-LP	12 "x20 "x6 "	11 " w/o legs 280mm	20¼ " 515mm	26¼ " 667mm	92lbs. 42kg	120	600	5
200-2-SL-LP	12 "x20 "x6 "	21 "w/o legs 534mm	20¼ " 515mm	26¼ " 667mm	142# 64kg	120	1200	10

Note: In line with its policy to continually improve its products, Wittco Foodservice Equipment reserves the right to change materials and specifications without notice.

Wittco Foodservice Equipment 7737 N 81st Street Milwaukee, WI 53223 USA

414-354-3080 800-367-8413 FAX 414-354-2821