

## MODEL 1001

### Cook and Hold Oven



UL Listed to Canadian safety standards  
Classified by UL to NSF Std. #4

## Specifications

Wittco Model 1001 Cook and Hold Oven with capacity for eight 18" x 26" sheet pans on 3" centers or sixteen 12" x 20" x 2 1/2" steam table pans. Mechanical controls capable of cooking at temperatures up to 250°F and holding at temperatures up to 190°F. Unit can also be used to rethermalize products. Knob style controls set the cooking time, cooking temperature and holding temperature while the timer automatically switches the unit from the cook to the hold cycle. The low speed fan provides even heat distribution and natural browning of meat products. Ovens come with 3 wire shelves. Unit comes with 20 gauge stainless steel inside and out, an integrated steel frame, full insulation, 5" heavy duty casters (2 swivel with brakes and 2 rigid) in a kit for field installation, magnetic action door latch plus a life time warranty on heating elements. Dual voltage 208/240 volt, single phase, 50/60 hz, complete with cord and plug (NEMA 6-30).

## Standard Features

- Cook and hold oven with capacity for
  - Eight 18" x 26" sheet pans on 3" centers
  - Or sixteen 12" x 20" x 2 1/2" steam table pans
- Cook at temperatures up to 250°F
- Hold at temperatures up to 190°F
- Timer automatically switches unit from cook to hold cycle
- Unit can also be used to rethermalize products
- Knob style controls set the cooking time, cooking temperature, and holding temperature
- Low speed fan provides even heat distribution and natural browning of meat products
- Provided with 3 wire shelves for cooking, adjustable tray slides are available as an accessory
- Interior and exterior are both constructed out of 20 gauge stainless steel
- Field reversible doors with predrilled holes
- Life time warranty on heating elements
- Integrated steel frame for maximum strength
- Fully insulated 2" in top and 1" in sides and bottom
- Magnetic action door latch and heavy duty hinges secured to internal frame
- 5" Heavy duty casters (2 swivel with brakes and 2 rigid) in a kit for field installation
- Dual voltage 208/240 volt, single phase, 50/60 hz.
- Complete with cord and plug (NEMA 6-30)

## Options

- Additional wire shelves
- Adjustable tray slide kit
- Full perimeter bumper
- Stacking kit

Approved by: \_\_\_\_\_

Date: \_\_\_\_\_

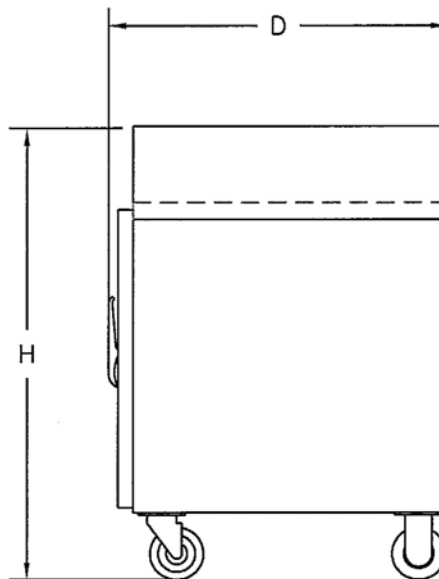
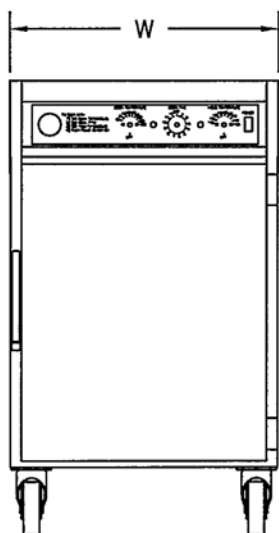
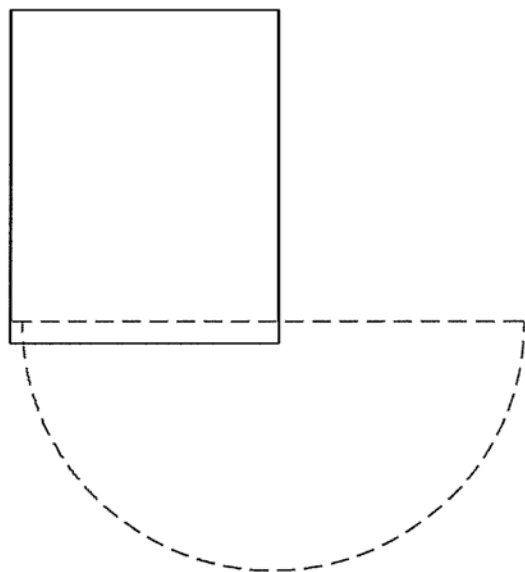

Model No	Capacity 18 "x26 "	Capacity 12 "x20 "x2½ "	High	Wide	Deep	Shipping Weight	Volts	Watts	Amps
1001	8	16	42.5 "	25.5 "	33 "	170# 78kg	208 240	2253 3000	10.8 12.5

Note: In line with its policy to continually improve its products, Wittco Foodservice Equipment reserves the right to change materials and specifications without notice.

Wittco Foodservice Equipment 7737 N 81st Street Milwaukee, WI 53223 USA

414-354-3080 800-367-8413 FAX 414-354-2821