

FRYERS

VULCAN**VK KLEENSCREEN PLUS® FILTRATION SYSTEM
BUILT-IN FILTRATION SYSTEM FOR 1VKF FRYERS**

Model 1VK45CF

**SPECIFICATIONS**

Built-in filter system, Vulcan-Hart Model No. 1VK (lb. capacity - 45, 65 or 85) (control type A, D, or C) F (add suffix-F to fryer battery model No., i.e. 1VK45DF). Filter system accommodates one 45 lbs., 65 lbs. or 85 lbs fryer. Filter vessel constructed of 18 gauge stainless steel. 1/3 H.P. motor/pump circulates hot frying compound at the rate of 8 gallons per minute, activated by a one touch push button switch. System provided standard with paperless stainless steel mesh filter screen. Optional KleenScreen PLUS® envelopes filter out particulate down to .5 microns (trial package included). Standard equipment comes on casters, tank brush, and clean-out rod. Hands free oil return line connection. Drain valve interlock switch turns fryer's burners off when drain valve is opened. Requires 120 volt, 50 / 60 Hz, 1 phase power supply. CSA design certified. NSF listed.

SPECIFY TYPE OF GAS WHEN ORDERING

- Natural Gas
 Propane Gas

SPECIFY ALTITUDE

The VK Series fryer does not require any special adjustments for varying altitudes ranging from 0 - 10,000 feet for either Natural or Propane gas.

STANDARD FEATURES

- Filter system accommodates 1VK45F, 1VK65F and 1VK85F.
- Choose from Solid State Knob Control (A) Solid State Digital (D), or Computer (C) Controls.
- Boil Out ByPass™ easily removes boil out solution from fry tank without contact of drain manifold, filter pan or motor/pump.
- Drain valve interlock switch turns off burners when drain valve is opened.
- 6" Casters adjustable - 2 locking, 2 non-locking.
- 18 gauge, stainless steel filter pan. 65 lbs. frying compound capacity on 1VK45F, 100 lbs. capacity on 1VK65F and 1VK85F.
- Paperless stainless steel filter screen filters from 2 sides filter area; 1VK45F=220 sq. inches; 1VK65F and 1VK85F=462 sq. inches. Micro Filtration Fabric Envelope filters out particulate down to .5 microns.
- 1/3 H.P. motor and pump circulates frying compound at a rate of 8.0 gallons per minute.
- 4' high temperature discard hose.
- One touch push button switch to engage pump and motor.
- Tank brush and clean-out rod.
- NEMA 5-15 for 120 volt, 50/60 Hz, 1 phase.
- One year limited parts and labor warranty.
- 10 year fry tank limited warranty.

ACCESSORIES (Packaged & Sold Separately)

- Stainless steel tank cover – doubles as a work surface top.
- Micro-Filtration Fabric Envelopes – 6 filters/per package.
- "Add-On" Frymate – VX15S, VX21S (Field Installed).
- 1VK45F – Twin Basket Lifts (Factory Installed).
- 1VK65F and 1VK85F – Single and Twin Basket Lifts (Factory Installed).
- Prison Security Package (Factory Installed).
- Flexible gas hose with quick disconnect.
- 10" high stainless steel splash guard.

OPTIONS

- Second year extended limited parts and labor warranty.

REFERENCE MATERIALS

- See 1VK45 Spec Sheet F32999.
- See 1VK65 Spec Sheet F45366.
- See 1VK85 Spec Sheet F45367.

VULCAN

a division of ITW Food Equipment Group LLC

P.O. Box 696 ■ Louisville, KY 40201 ■ Toll-free: 1-800-814-2028 ■ Local: 502-778-2791 ■ Quote & Order Fax: 1-800-444-0602



VK KLEENSCREEN PLUS® FILTRATION SYSTEM
BUILT-IN FILTRATION SYSTEM FOR 1VKF FRYERS

INSTALLATION INSTRUCTIONS

1. A combination valve with pressure regulator is provided with this unit. Natural Gas 4.0" (102 mm) W.C. Propane Gas 10.0" (254 mm) W.C.
2. An adequate ventilation system is required for Commercial Cooking Equipment. Information may be obtained by writing to the National Fire Protection Association, Batterymarch Park, Quincy, MA 02269. When writing refer to NFPA No. 96.
3. All models require a 6" (152 mm) clearance at both sides and rear adjacent to combustible construction.
4. All models require a 16" (407 mm) minimum clearance to adjacent open top burner units.

5. This appliance is manufactured for commercial installation only and is not intended for home use.

SERVICE CONNECTIONS:

- Ⓟ 1/2" (12.7 mm) I.D. and 3/4" (19 mm) O.D. NPT common rear gas connection.
- Ⓜ NEMA 5-15P, 120 volt, 60 Hz, 1 phase electrical connection (filter pump).

NOTE: In line with its policy to continually improve its product, Vulcan reserves the right to change materials and specifications without notice.

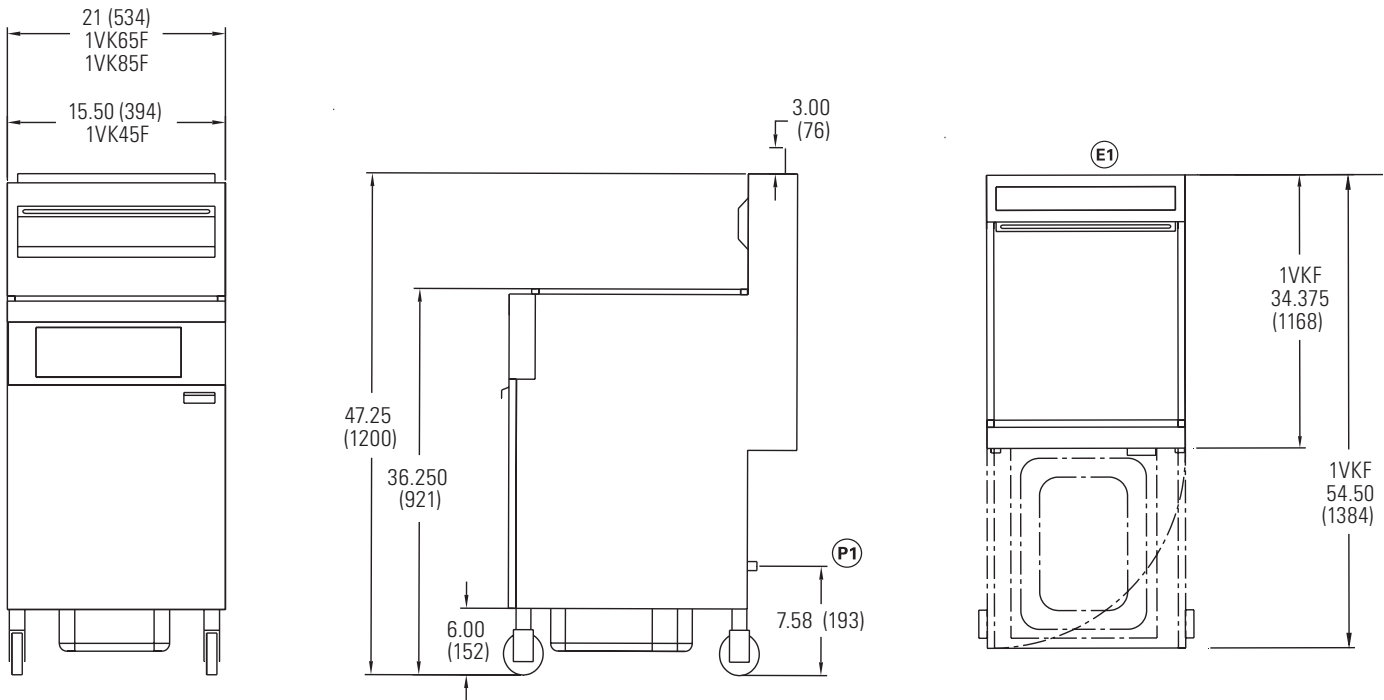

Model	Filter Pan Capacity	Filter Screen Fabric Envelope	Motor	Pump	Electric / Amps	Electric / Power
1VK45F	65 lbs.	220 sq. in. 225 sq. in.	1/3 H.P. 1750 RPM	8 Gal/Min	115V 5.0A	115V 50/60Hz 1Ph
1VK65F	100 lbs.	462 sq. in. 515 sq. in.	1/3 H.P. 1750 RPM	8 Gal/Min	115V 5.0A	115V 50/60Hz 1Ph
1VK85F	100 lbs.	462 sq. in. 515 sq. in.	1/3 H.P. 1750 RPM	8 Gal/Min	115V 5.0A	115V 50/60Hz 1Ph

This appliance is manufactured for commercial use only and is not intended for home use.



a division of ITW Food Equipment Group LLC

P.O. Box 696 ■ Louisville, KY 40201 ■ Toll-free: 1-800-814-2028 ■ Local: 502-778-2791 ■ Quote & Order Fax: 1-800-444-0602