

## GRIDDLES &amp; BROILERS

**VULCAN****36SBI**  
**36" HEAVY DUTY GAS**  
**INFRARED SALAMANDER BROILER**

Model 36SBI

**SPECIFICATIONS**

Gas infrared salamander broiler, Vulcan-Hart Model No. 36SBI. Stainless steel front, top and sides. 30,000 BTU/hr. heavy duty infrared burner. Infinite heat control valve. Standing pilot ignition system. Chrome plated trigger grip control handle provides positive positioning of the broiling carriage. Heavy duty chrome plated broiling grid measures 27½" w x 13"d. Removable full width spillage pan. ¾" top connection and gas pressure regulator.

**Exterior Dimensions:**

36" w x 19" d x 17<sup>5</sup>/<sub>8</sub>" h (broiler dimensions only).

CSA design certified. NSF listed.

**SPECIFY TYPE OF GAS WHEN ORDERING.**  
**SPECIFY ALTITUDE WHEN ABOVE 2,000 FT.**

**36SBI** Salamander Broiler

**NOTE:** 36SBI may be used in conjunction with appropriate reinforced range back riser, wall mounted with optional brackets or counter mounted with optional 4" legs.

**STANDARD FEATURES**

- Stainless steel front, top and sides.
- 30,000 BTU/hr. heavy duty infrared burner.
- Infinite adjustment temperature control.
- Standing pilot ignition system.
- Chrome plated trigger grip control handle provides positive positioning of the broiling carriage. Heavy duty chrome plated broiling grid measures 27½" w x 13" d.
- Removable full width spillage pan.
- ¾" top gas connection and gas pressure regulator.
- One year limited parts and labor warranty.

**OPTIONS**

- Set of stainless steel wall mount brackets.
- Set of 4" legs with adjustable feet.
- Stainless steel reinforced back riser for range mounting.

**VULCAN**

a division of ITW Food Equipment Group LLC

P.O. Box 696 ■ Louisville, KY 40201 ■ Toll-free: 1-800-814-2028 ■ Local: 502-778-2791 ■ Quote & Order Fax: 1-800-444-0602



## 36SBI 36" HEAVY DUTY GAS INFRARED SALAMANDER BROILER

**INSTALLATION REQUIREMENTS:**

1. A gas pressure regulator sized for this unit is included. Natural gas 6" W.C., Propane gas 10" W.C.
2. An adequate ventilation system is required for commercial cooking equipment. Information may be obtained by writing to the National Fire Protection Association, Batterymarch Park, Quincy, MA 02169. When writing refer to NFPA No. 96.
3. These units are manufactured for installation in accordance with National Fuel Gas Code, ANSI-Z223.1/NFPA #54 (latest edition). Copies may be obtained from The American Gas Association, Accredited Standards Committee Z223 @ 400N. Capital St. NW,

Washington, DC 20001, or the Secretary Standards Council, NFPA, 1 Batterymarch Park, Quincy, MA 02169-7471.

**NOTE: In the Commonwealth of Massachusetts**

All gas appliances vented through a ventilation hood or exhaust system equipped with a damper or with a power means of exhaust shall comply with 248 CMR.

- |                |             |                 |
|----------------|-------------|-----------------|
| 4. Clearances: | Combustible | Non-Combustible |
| Rear           | 0"          | 0"              |
| Sides          | 2"          | 0"              |
| Bottom         | 10"         | 4"              |
5. This appliance is manufactured for commercial installation only and is not intended for home use.

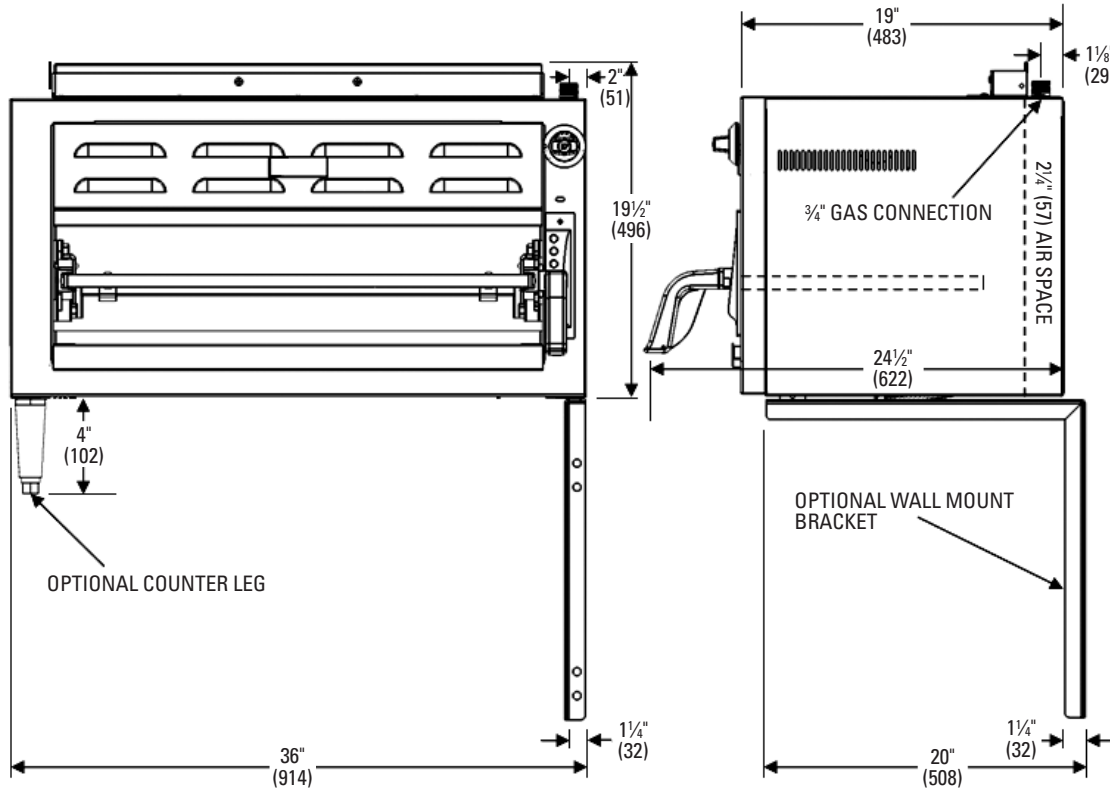

**GAS CONNECTION: 3/4" (19 mm)**

| MODEL | MOUNTED OVER | INPUT BTU/hr. | WIDTH          | DEPTH        | HEIGHT      | APPROX. SHIP. WT. |
|-------|--------------|---------------|----------------|--------------|-------------|-------------------|
| 36SBI | 36" range    | 30,000        | 36" (914 mm)   | 19" (483 mm) | See Drawing | 250 lbs./113 kg   |
| 36SBI | 48" range    | 30,000        | *48" (1219 mm) | 19" (483 mm) |             | 275 lbs./125 kg   |
| 36SBI | 60" range    | 30,000        | *60" (1524 mm) | 19" (483 mm) |             | 300 lbs./136 kg   |

\*Width includes broiler and single deck plate shelf.



a division of ITW Food Equipment Group LLC

P.O. Box 696 ■ Louisville, KY 40201 ■ Toll-free: 1-800-814-2028 ■ Local: 502-778-2791 ■ Quote & Order Fax: 1-800-444-0602