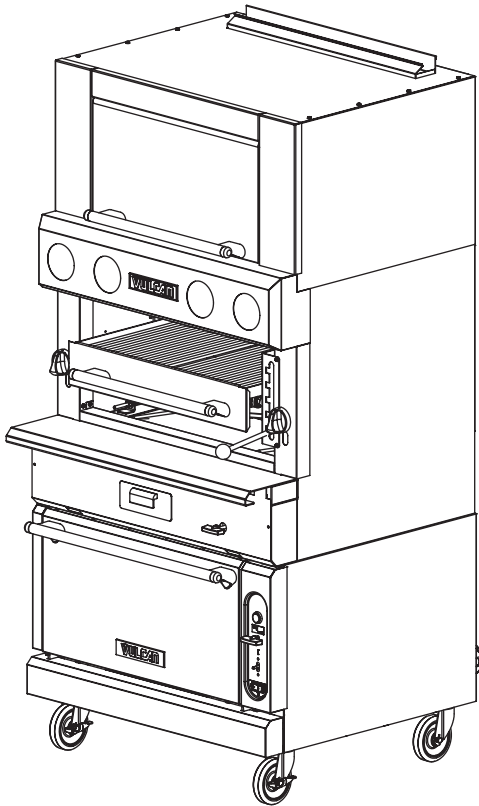

**HEAVY DUTY COOKING****VULCAN****HEAVY DUTY GAS RANGE  
INFRARED UPRIGHT BROILERS  
36" WIDE GAS RANGE****Model VIR1CF**

(shown on a convection oven base with optional finishing oven)

**SPECIFICATIONS**

36" wide heavy duty gas range, Vulcan Model No. VIR1F (modular), VIR1BF (cabinet base), VIR1SF (standard oven base), or VIR1CF (convection oven base). Stainless steel front, front top ledge, sides, base, stub back and top. 1 $\frac{1}{4}$ " diameter front gas manifold. Four 25,000 BTU/hr. ceramic tile faced infrared burners. **Standard Oven:** 50,000 BTU/hr. with porcelain oven bottom, side and indoor panel. **Convection Oven:** 32,000 BTU/hr. with porcelain oven bottom, side and interior door panel (115v-1 phase blower motor, 4 amps, 9' cord and plug). Oven measures 27" w x 27" d x 13" h. Standard oven thermostat adjusts from 150° – 550°F, Convection oven from 175° – 550°F, and the optional 650° oven for standard ovens, 300° – 650°F. Total input 100,000 BTU/hr.

**Exterior Dimensions:**41 $\frac{7}{8}$ " d x 36" w x 77 $\frac{1}{2}$ " h on casters

- VIR1F** Modular (\* for refrigerated base mount only)
- VIR1BF** Cabinet Base
- VIR1SF** Standard Oven Base
- VIR1CF** Convection Oven Base

**STANDARD FEATURES**

- Stainless steel front, front top ledge, sides, base, and stub back with 1 $\frac{1}{4}$ " rear gas connection (capped)
- 1 $\frac{1}{4}$ " diameter front gas manifold
- Four each 25,000 BTU/hr. infrared burners (22,500 BTU/hr – propane)
- 50,000 BTU/hr. standard oven burner
- 32,000 BTU/hr. convection oven burner
- Pilot ignition system
- Off/Low/High heat controls – 2 each
- Spring balanced, 5 position grid
- Full width, floating s/s drip pan
- 25.5" w x 24.5" d cooking grid. (625 sq. inches)
- Grid of cold rolled steel bar
- 6" adjustable stainless steel legs for "S", "B" and "C" models
- Universal rack guides, one removable shelf on "B" models
- One year limited parts and labor warranty

**OPTIONAL FEATURES (Factory Installed)**

- Cap and cover front manifold
- Stainless steel oven cavity, burner box and exterior range bottom
- 650°F oven thermostat and steel hearth. ("S" models)
- Fan cooling package. ("C" models)
- Less legs for dolly mounting of cabinet base models
- 3" high toe base for curb mounting for "S", "B", and "C" models

**ACCESSORIES (Packaged & Sold Separately)**

- $\frac{3}{4}$ ", 1", or 1 $\frac{1}{4}$ " gas pressure regulator (specify gas type – pack loose)
- Set of 4 casters, 6" high (two locking)
- 6" adjustable flanged feet for cabinet base models
- Extra removable shelves for use with Universal rack guides (for cabinet base)
- Banking strip
- Common condiment type, telescoping plate rails
- Flexible gas hose with quick disconnect & restraining device

**VULCAN**

a division of ITW Food Equipment Group LLC

P.O. Box 696 ■ Louisville, KY 40201 ■ Toll-free: 1-800-814-2028 ■ Local: 502-778-2791 ■ Quote &amp; Order Fax: 1-800-444-0602



**HEAVY DUTY GAS RANGE  
INFRARED UPRIGHT BROILERS  
36" WIDE GAS RANGE**

**INSTALLATION INSTRUCTIONS**

1. A properly sized gas pressure regulator suitable for battery or single unit application must be furnished and installed. Natural gas 6.0" W.C., propane gas 10.0" W.C.
  2. An adequate ventilation system is required for commercial cooking equipment. Information may be obtained by writing to the National Fire Protection Association, 1 Batterymarch Park, Quincy, MA 02269, www.NFPA.org. When writing, refer to NFPA No. 96.
  3. These units are manufactured for installation in accordance with ANSZ223.1A (latest edition), National Fuel Gas Code. Copies may be obtained from The American Gas Association, 400 N Capitol St. NW, Washington, DC 20001, www.AGA.org.
  4. **Clearances**  

	Rear	Sides
Combustible	10"	10"
Non-combustible	0"	0"
  5. For proper combustion, install equipment on adjustable legs or casters. On curb or platform, allow 3½" front overhang. Toe base with leveling bolts are required for curb installation. Specify when ordering.
  6. Cannot be battered with GH series equipment.
  7. This appliance is manufactured for commercial installation only and is not intended for home use.
- NOTE:** In line with its policy to continually improve its product, Vulcan reserves the right to change materials and specifications without notice.

**Specify type of gas when ordering.  
Specify altitude when above 2,000 feet.**

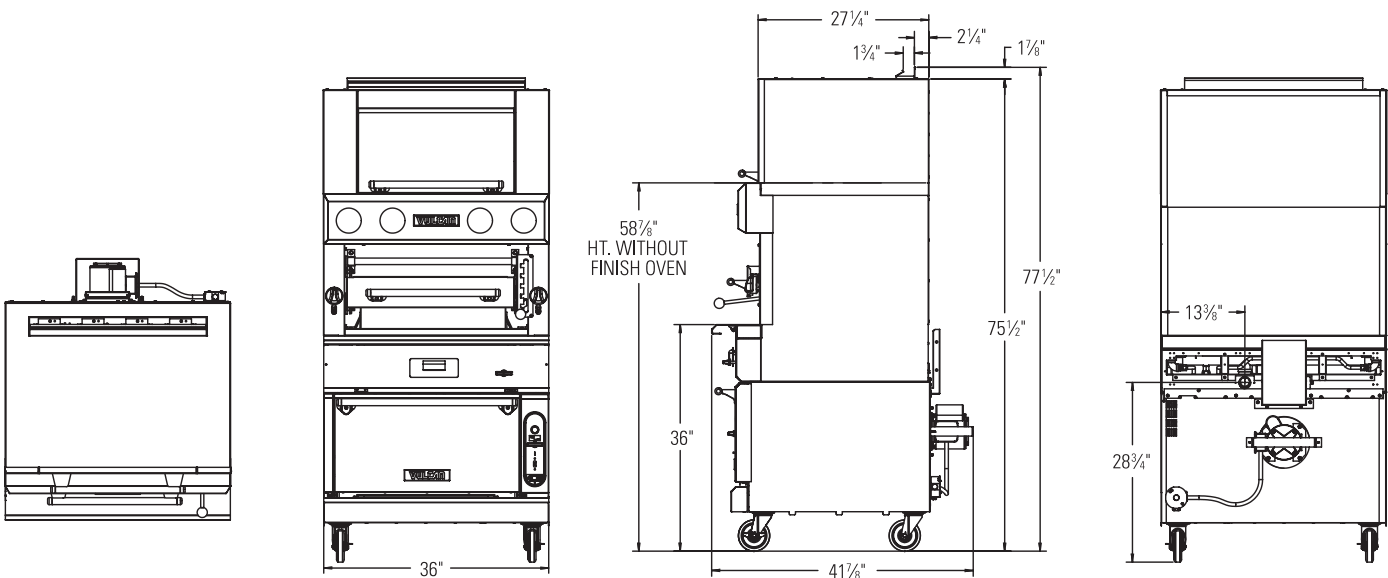

MODEL NUMBER	DESCRIPTION	TOTAL INPUT BTU / HR	SHIPPING WEIGHT LBS / KG
<b>VIR1F</b>	Upright Infrared Broiler / Modular*	100,000	675 / 304
<b>VIR1BF</b>	Upright Infrared Broiler / Cabinet Base	100,000	675 / 304
<b>VIR1SF</b>	Upright Infrared Broiler / Standard Oven Base	150,000	765 / 344
<b>VIR1CF</b>	Upright Infrared Broiler / Convection Oven Base	132,000	875 / 394



a division of ITW Food Equipment Group LLC

P.O. Box 696 ■ Louisville, KY 40201 ■ Toll-free: 1-800-814-2028 ■ Local: 502-778-2791 ■ Quote & Order Fax: 1-800-444-0602

**NOTE:** In line with its policy to continually improve its products, Vulcan reserves the right to change materials and specifications without notice.