

## MODEL VST4B

HEAVY DUTY GAS CERAMIC  
CHOP HOUSE BROILER



- VST4B Ceramic Broiler with Griddle Plate

### STANDARD FEATURES

- Stainless steel front, sides, leg stand, with 6" casters and shelf.
- 3/4" diameter rear gas connection.
- Three 45,000 BTU/hr. ceramic burners, 135,000 BTU/hr. input.
- Standing pilot ignition system.
- Three infinite heat control valves.
- Floating grid rack assembly with positive positioning control handle. Four grid positions. Broiler grid measures 35 1/2" w x 27" d.
- 1/2" griddle plate with 2" splashes.
- Front mounted grease receptacle and side mounted hanging grease container for griddle plate.
- Griddle/Broiler brush.
- Standard 56" high griddle cooking surface.
- One year limited parts and labor warranty.

### OPTIONS

- 4" shorter leg stand with casters.

### ACCESSORIES

- 1 1/4" x 4 foot quick disconnect hose with restraining device.
- Additional griddle/broiler brush.



### SPECIFICATIONS

Heavy duty single section gas over fired ceramic broiler with 1/2" griddle plate, Vulcan-Hart Model No. VST4B. S/S front, sides, leg stand and 6" high casters with 5" wheels. 3/4" diameter rear gas connection, supplied with a 1 1/4" gas regulator and reducer. Three 45,000 BTU/hr. ceramic burner, 135,000 BTU/hr. input. Standing pilot ignition system. Three infinite heat control valves. Floating grid rack assembly with positive positioning control handle. Four grid positions. Achieves 950° across the cooking grid. Achieves 650° across the griddle top. Broiler grid measures 35 1/2" w x 27" d.

Exterior dimensions: 45 1/2" w x 34 3/16" d x 56 1/4" h on leg stand with casters.

CSA design certified. NSF listed.

SPECIFY TYPE OF GAS WHEN ORDERING.

SPECIFY ALTITUDE WHEN ABOVE 2,000 FT.



# MODEL VST4B

HEAVY DUTY GAS CERAMIC  
CHOP HOUSE BROILER

### IMPORTANT

1. A gas pressure regulator suitable for this application is furnished and must be installed. Natural gas 6.0" W.C., propane gas 10" W.C.
2. An adequate ventilation system is required for commercial cooking equipment. Information may be obtained by writing to the National Fire Protection Association, Batterymarch Park, Quincy, MA 02289. When writing, refer to NFPA No. 96.
3. These units are manufactured for installation in accordance with ANSZ223.1A (latest edition), National Fuel Gas Code. Copies may be obtained from the American Gas Association, 1515 Wilson Blvd., Arlington, VA 22209.
4. All models require a 6" (152 mm) clearance at both sides and rear adjacent to combustible construction.
5. This appliance is manufactured for commercial installation only and is not intended for home use.

Shipping Weight: 986 lbs.

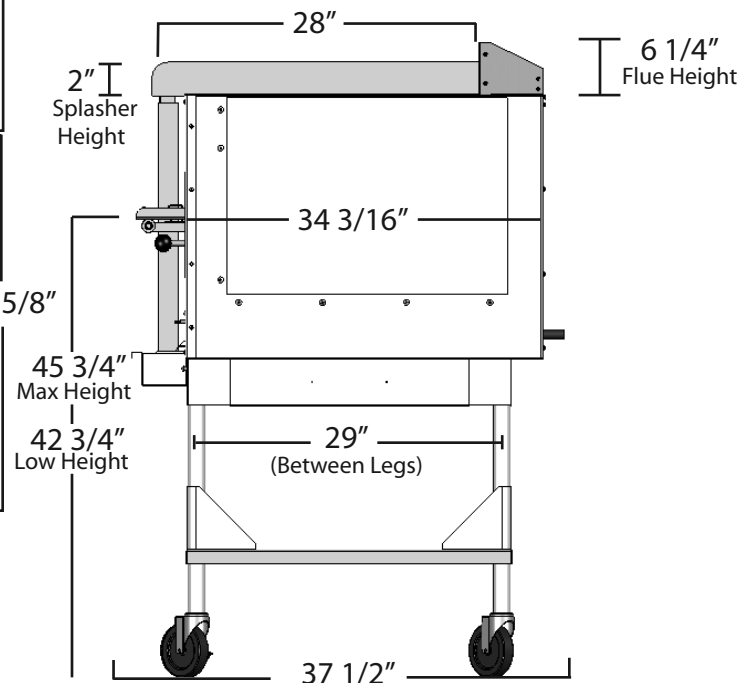
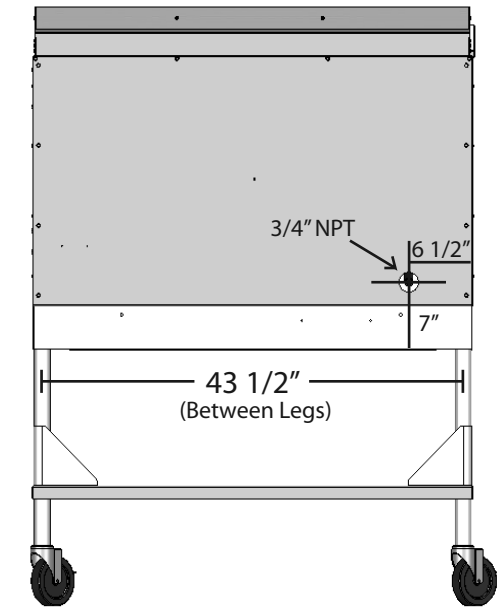
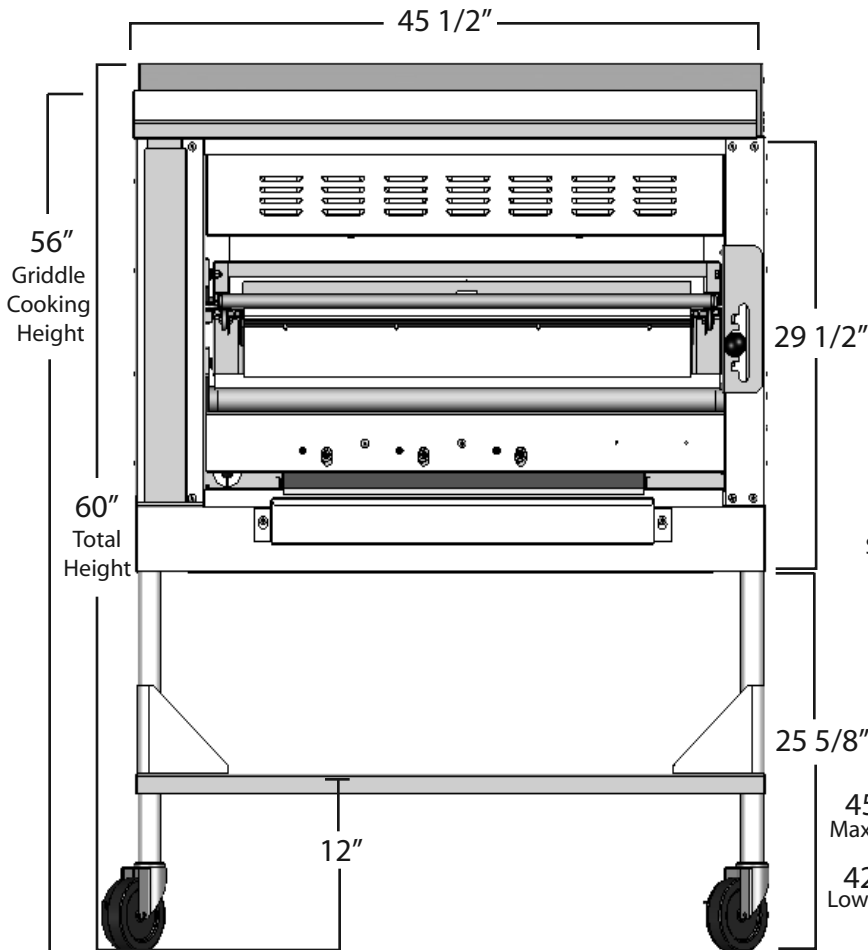

NOTE: In line with its policy to continually improve its products, Vulcan-Hart Company reserves the right to change materials and specifications without notice.