

**FRYERS****VULCAN****GR KLEENSCREEN PLUS® FILTRATION SYSTEM  
BUILT-IN FILTER SYSTEM FOR 2GRF, 3GRF & 4GRF FRYERS****Model 2GR45DF****SPECIFICATIONS**

Built-in filter system, Vulcan-Hart Model No. (# of fryers 2, 3, 4) GR (45, 65, 85) (control type M, A, D, or C) F (add suffix-F to fryer battery model No., i.e. 2GR45DF). Filter system accommodates maximum of four cabinets for GR45F and maximum of three for GR65F and GR85F. Filter vessel constructed of drawn (seamless) 18 gauge series stainless steel. The 2GR45F filter pan weighs only 12.2 lbs. and the filter pan for the 2GR65 & GR85F weighs only 20.5 lbs. 1/3 H.P. motor/pump circulates hot frying compound at the rate of 8 gallons per minute, activated by a one touch push button switch. System provided standard with paperless stainless steel mesh filter screen. Optional KleenScreen PLUS® envelopes filter out particulate down to .5 microns (trial package included). Standard equipment comes on casters, has a tank brush, and clean-out rod. Hands free oil return line connection. Drain valve interlock switch turns fryer's burners off when drain valve is opened on (A), (D) and (C) controls. Requires 120 volt, 60 Hz, 1 phase power supply.

CSA design certified. NSF listed.

**SPECIFY TYPE OF GAS WHEN ORDERING**

- Natural Gas  
 Propane Gas

**SPECIFY ALTITUDE**

- Natural Gas for above 2,000 ft.  
 Propane Gas for above 3,500 ft.

**STANDARD FEATURES**

- Filter system accommodates maximum of four fryer cabinets (GR45F), maximum of three (GR65F or GR85F).
- Boil Out ByPass™ easily removes boil out solution from fry tank without contact of drain manifold, filter pan or motor/pump.
- Drain valve interlock switch – turns off gas burners automatically when draining oil on (A), (D), and (C) controls.
- 6" Casters adjustable – 2 locking, 2 non-locking.
- Drawn (seamless) 18 gauge stainless steel filter pan. 70 lbs. frying compound capacity on GR45F, 110 lbs. capacity on GR65 & GR85F.
- Paperless stainless steel filter screen filters from 2 sides filter area = 270 square inches. Micro Filtration Fabric Envelope filters out particulate down to .5 microns.
- 1/3 H.P. motor and pump circulates frying compound at a rate of 8.0 gallons per minute.
- One touch push button switch to engage pump and motor (solid state controls (A) & (D) and computer (C) models only).
- Tank brush and clean-out rod.
- 120 volt, 60 Hz, 1 phase (NEMA 5-15P).
- One year limited parts and labor warranty.
- 10 year fry tank limited warranty.
- 6' High Temperature Discard Hose.

**ACCESSORIES (Packaged & Sold Separately)**

- Stainless steel tank cover – doubles as a work surface top.
- Micro-Filtration Fabric Envelopes – 6 filters/per package.
- "Add-On" Frymate™ – VX15 or VX21S.
- Rear oil reclamation discard connection (Factory Installed).
- GR45F – Twin Basket Lifts (Factory Installed).
- GR65F & GR85F – Single and Twin Basket Lifts (Factory Installed).
- Prison Security Package (Factory Installed).
- Flexible gas hose with quick disconnect.

**OPTIONS**

- Second year extended limited parts and labor warranty.

**REFERENCE MATERIALS**

- See 1GR45 Spec Sheet F32630.
- See 1GR65 Spec Sheet F32631.
- See 1GR85 Spec Sheet F32632.
- See 1GRF Spec Sheet F32962 for single unit KleenScreen PLUS®.

**VULCAN**

a division of ITW Food Equipment Group LLC

P.O. Box 696 ■ Louisville, KY 40201 ■ Toll-free: 1-800-814-2028 ■ Local: 502-778-2791 ■ Quote &amp; Order Fax: 1-800-444-0602



**GR KLEENSCREEN PLUS® FILTRATION SYSTEM**  
**BUILT-IN FILTER SYSTEM FOR 2GRF, 3GRF & 4GRF FRYERS**

**INSTALLATION INSTRUCTIONS**

1. A combination valve with pressure regulator is provided with this unit.
  - Natural Gas 4.0" (102 mm) W.C.
  - Propane Gas 10.0" (254 mm) W.C.
2. An adequate ventilation system is required for Commercial Cooking Equipment. Information may be obtained by writing to the National Fire Protection Association, Batterymarch Park, Quincy, MA 02269. When writing refer to NFPA No. 96.
3. All models require a 6" (152 mm) clearance at both sides and rear adjacent to combustible construction.
4. All models require a 16" (407 mm) minimum clearance to adjacent open top burner units.

5. This appliance is manufactured for commercial installation only and is not intended for home use.

**Service Connections:**

- Ⓟ 1 1/4" (32 mm) NPT common rear gas connection.
- Ⓜ 120 volt, 60 Hz, 1 phase electrical connection (NEMA 5-15P).

**NOTE:** In line with its policy to continually improve its product, Vulcan reserves the right to change materials and specifications without notice.

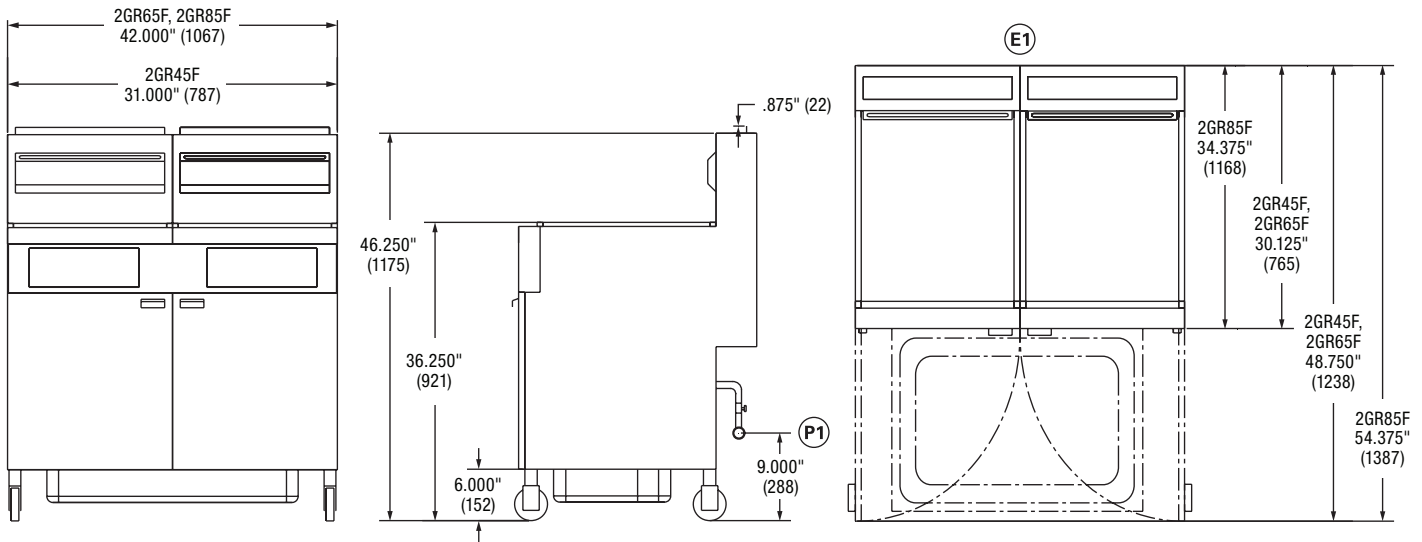

**Views**  
**Front, Side and Top**  
 2GR45F, 2GR65F, 2GR85F,

Model	Filter Pan Capacity	Filter Area / Fabric Envelope	Motor	Pump	Electric Amps	Electric Power	Battery Dimensions (Widths)		
							2 Fryers	3 Fryers	4 Fryers
GR45F	70 lbs.	270 sq. in 350 sq. in	1/3 HP 1750 RPM	8 Gal/Min	115V 5.0A	115V 60Hz 1Ph	31"	46 1/2"	62"
GR65F	110 lbs.	270 sq. in 350 sq. in	1/3 HP 1750 RPM	8 Gal/Min	115V 5.0A	115V 60Hz 1Ph	42"	63"	—
GR85F									

This appliance is manufactured for commercial use only and is not intended for home use.



a division of ITW Food Equipment Group LLC

P.O. Box 696 ■ Louisville, KY 40201 ■ Toll-free: 1-800-814-2028 ■ Local: 502-778-2791 ■ Quote & Order Fax: 1-800-444-0602