

# FB1222 – 1200 lb Flake Ice Machine

Prodigy® Advanced Sustainability Modular Nugget Ice Maker **PRELIMINARY**



Shown on B948S bin with optional KLP8S legs.

## Features

The path to a more sustainable operation is through Prodigy Advanced Sustainability™. Integrated controls for optimizing energy and water efficiency and enhanced service diagnostic capability, help operations save money and natural resources.

Ultimate ice level management with a programmable seven-day 15 set-point system. Choose the amount of ice you need, when you want to make it.

An advanced network control system provides information about the machine's performance history to maximize operational uptime. If an issue does occur, Prodigy Advanced Sustainability can self-diagnose the issue and benchmark it. Maintenance can be accomplished faster and more effectively.

Visually communicates the machine's current status through five easy-to-understand LED-lighted universal symbols. Immediately alerts staff to key operational issues to minimize performance interruptions and ensure maintaining appropriate ice production levels. Tone/buzzer feature reinforces light symbols.

Warranty start date is stored in the controls for easy access and preventative maintenance scheduling as well as asset control management.

Preventative maintenance is simpler than ever with easily-removed panels allowing clear access to internal components. Reusable air filter is easily removable from the outside.

Prodigy Flake Ice machines are highly efficient, using up to 50% less water and 15% less energy than cube ice machines.

## 24 Hour Volume Production

Air Cooled		
70°F/21°C	Air	AHRI
50°F/10°C	Water	90°F/32°C
lb/kg		70°F/21°C
		lb/kg
1100/499		825/374

## Flake Ice



Cools more quickly than other ice forms. Used in produce and fish displays.



Certified to NSF/ANSI 61-G

## Modular Bin Options

Model Number	Dimensions W" x D" x H"	AHRI Certified Bin Capacity lb/kg	Application Capacity lb/kg	Ship Weight lb/kg
B948S*	48 x 34 x 44**	893/406	700/319	220/100
BH1100BB/SS	48 x 34 x 50**	1100/499	860/390	280/127
BH1300BB/SS	60 x 34 x 50**	1400/635	1100/499	310/140
BH1600BB/SS	60 x 34 x 62**	1755/796	1375/624	370/168

\* Contact Scotsman for bin top requirements. \*\*Add 6" H for bin legs.

FB1222 shown side  
by side on B948S bin.



Nature's antimicrobial



## Warranty

- 3 years parts and labor on all components.
- 5 years parts and the compressor.

Warranty valid in North, South & Central America. Contact factory for warranty in other regions.

Installation Note: Allow 6" space at left, back and right side for ventilation and utility connections.

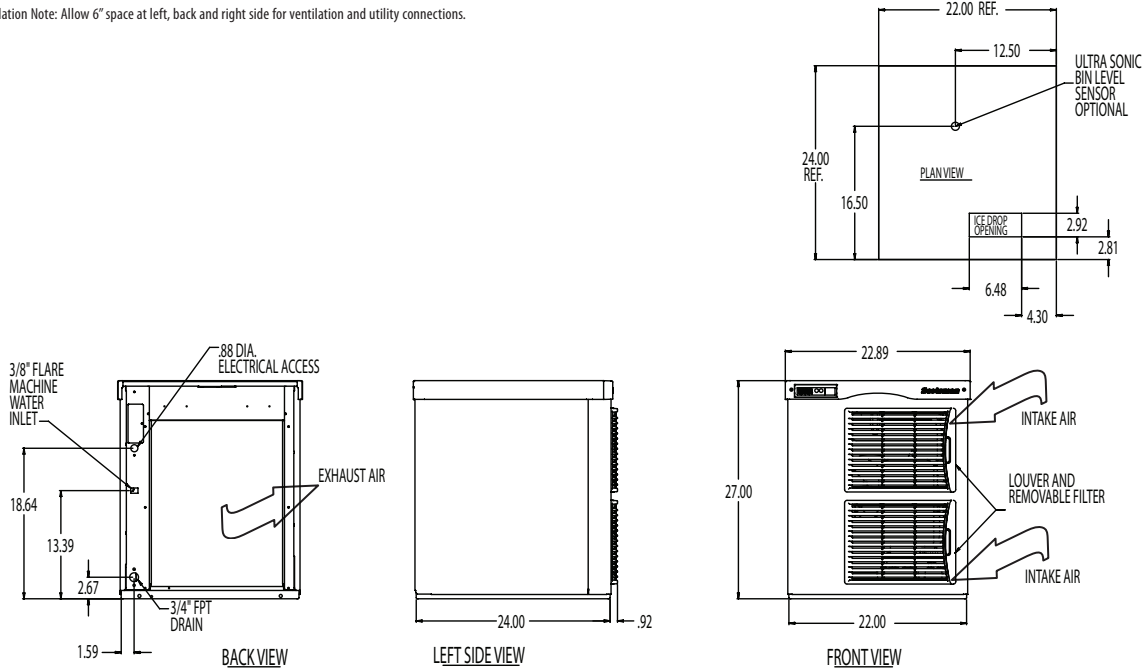

## Specifications

Model Number* Cube Size: small	Condenser Unit	Basic Electrical Volts/Hz/Phase	Max. Fuse Size or HACR Circuit Breaker (amps)	Circuit Wires	Min. Circuit Ampacity	Energy Consumption kWh/100 lb (45.4 kg) 90°F(32°C)/70°F(21°C)	Water Usage Gallons/100 lb (liters/45.4 kg)	
							Potable 90°F(32°C)/ 70°F(21°C)	Condenser 90°F(32°C)/ 70°F(21°C)
FB1222A-32	Air	208-230/60/1	15	2	12.5	3.9	12.0/45.5	-

## All Models

Dimensions (W x D x H):  
 Unit:  
 22.9" x 24" x 27"  
 (58.2 x 61.0 x 68.6 cm)

Shipping Carton:  
 25.5" x 27.5" x 32.5"  
 (64.8 x 69.9 x 82.6 cm)

Shipping Weight:  
 220 lb / 100 kg

BTUs per hour:  
 10,500

Refrigerant:  
 R-404A

## Accessories

Model Number	Description
KPFS227	Side Air Flow Kit for 27" Tall Prodigy Flaker and Nugget

\* Scotsman recommends all ice machines have water filtration. See Scotsman Sanitation Matrix for details.

## Operating Requirements

	Minimum	Maximum
Air Temperatures	50°F (10°C)	100°F (38°C)
Water Temperatures	40°F (4.4°C)	100°F (38°C)
Remote Cond. Temps	-20°F (-29°C)	120°F (49°C)
Water Pressures	20 PSIG (1.4 bar)	80 PSIG (5.5 bar)
Electrical Voltage	-10%	+10%

Specifications and design are subject to change without notice.

Scotsman Ice Systems · 775 Corporate Woods Parkway · Vernon Hills, IL 60061

1-800-SCOTSMAN

Fax: 847-913-9844

E-mail: customer.relations@scotsman-ice.com

www.scotsman-ice.com