

# LEXINGTON DELI

ITEM: \_\_\_\_\_ QUANTITY: \_\_\_\_\_

## MODEL # SCBD

SCBD - Shown with optional multi inlayed horizontal laminates.

### SPECIFICATIONS

The SCBD is a refrigerated Deli display case with a choice of standard grade laminate exterior ends and insulated curved front glass.



- Available depths:  35 3/4"
- Available lengths:  36"  48"  60"  
 72"  96"

### STANDARD FEATURES

- Curved Insulated Fixed Glass
- Standard Grade Laminate Exterior
- Top Canopy Light
- 2 Stainless Steel Shelves with Lights
- Stainless Steel Deck Pan
- Mirrored Interior Ends
- Mirrored Rear Sliding Doors
- 115V/60/Single Phase
- UL Listed in Accordance with NSF 7
- Built-In Condensate Evaporator
- 134A Refrigerant
- Black Base
- Thermometer

### OPTIONAL FEATURES

- Stainless Steel Exterior Finish
- Special Laminates
- Wood Veneers (Unfinished)
- Wood Veneers (Stained & Sealed)
- Miscellaneous Trim
- Promolux Lighting (Low UV)
- Brass Trim and Hardware
- Wire Shelves
  - White  Chrome
- Casters
- Bullet Feet
- Rear Fold Down Work Ledge
- Rear Door Locks
- 5 Year Compressor Warranty
- Remote Refrigeration

### WHEN ORDERING, PLEASE SPECIFY:

APPLICATION: \_\_\_\_\_

REFRIGERATION TYPE: \_\_\_\_\_

LAMINATE COLOR: \_\_\_\_\_

# LEXINGTON DELI

TOLL FREE: 800-525-3692

## MODEL # SCBD

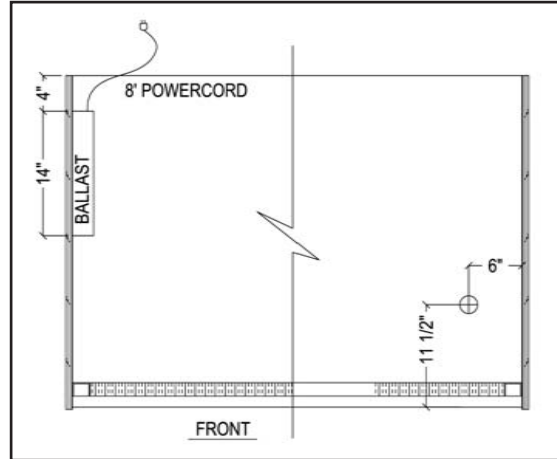
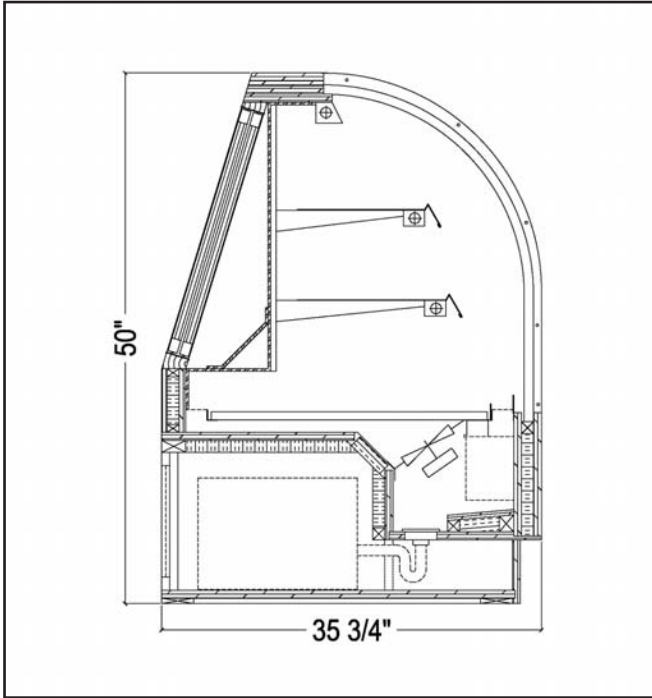

### Electrical & Plumbing locations



Refrigerated Case Display 67C9 Listed  
Also classified by Underwriters Laboratories Inc.  
In Accordance with ANSI/NSF 7-1999 and ANSI/NSF 2-1999

MODEL	L	D	H	COMP HP	VOLT	AMP	NEMA PLUG	WT
SCBD36R	36	35 3/4	50	1/3	115V	9.3	5-15P	600
SCBD48R	48	35 3/4	50	1/3	115V	9.3	5-15P	700
SCBD60R	60	35 3/4	50	1/3	115V	9.3	5-15P	800
SCBD72R	72	35 3/4	50	1/2	115V	12.3	5-20P	900
SCBD96R*	96	35 3/4	50	1/2	115V	13.3	5-20P	1100

\* SCBD96R requires a floor drain. No evaporation pan available.

The SCBD merchandiser is designed for use in stores where temperature and humidity do not exceed 75 degrees F and 55% R. H. Locate away from direct sunlight, rapid air currents and extreme temperature changes. Any adverse conditions will affect warranty.

RPI in line with its policy to continually improve its product reserves the right to change materials and specifications without notice.

CALL TOLL FREE: 800-525-3692 (609-714-2330)

FAX: 609-714-2331 [www.regalpinnacl.com](http://www.regalpinnacl.com)

220 ROUTE 70, MEDFORD, NJ 08055

**RPI** REGAL PINNACLE INTEGRATIONS INDUSTRIES, INC.