

EXPRESS BAKERY

ITEM: _____ QUANTITY: _____

MODEL # SCXB

SCXB - Shown with standard features.

SPECIFICATIONS

The SCXB is a metal framed refrigerated display case with a choice of standard grade plastic laminate exterior ends and lift-up tempered curved front glass for easy cleaning and stocking. *Also available in non-refrigerated.



Available depths: 37 1/2"

Available lengths: 45 7/8" 57 7/8" 69 7/8"

77 5/8" 90 1/4"

NOTE: Cannot fit through a 36" opening.

STANDARD FEATURES

- Self-Contained Refrigeration
- Metal Framed
- Stainless Steel Noser Panel
- Stainless Steel Back
- Standard Grade Laminate Exterior
- Top Canopy Light
- 3 Tempered Glass Shelves with Lights
- Stainless Steel Deck Pan
- Black Base
- Thermometer
- Built-In Condensate Evaporator
- Cord and Plug
- 115V/60/Single Phase
- UL Listed in Accordance with NSF 7
- 134A Refrigerant

OPTIONAL FEATURES

- Stainless Steel Exterior Finish
- Special Laminates
- Wood Veneers (Unfinished)
- Wood Veneers (Stained & Sealed)
- Miscellaneous Trim
- Mirrored Interior Ends
- Mirrored Rear Sliding Doors
- Front Glass Locks
- Rear Door Locks
- Promolux Lighting (Low UV)
- Brass Trim and Hardware
- Wire Shelves
 - Brass White Black Chrome
- Casters
- Bullet Feet
- Glass Vision End panels
- 5 Year Compressor Warranty
- Remote Refrigeration

WHEN ORDERING, PLEASE SPECIFY:

APPLICATION: _____

REFRIGERATION TYPE: _____

LAMINATE COLOR: _____

EXPRESS BAKERY

TOLL FREE: 800-525-3692

MODEL # SCXB

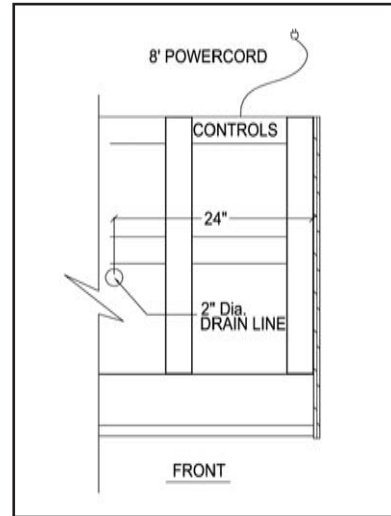
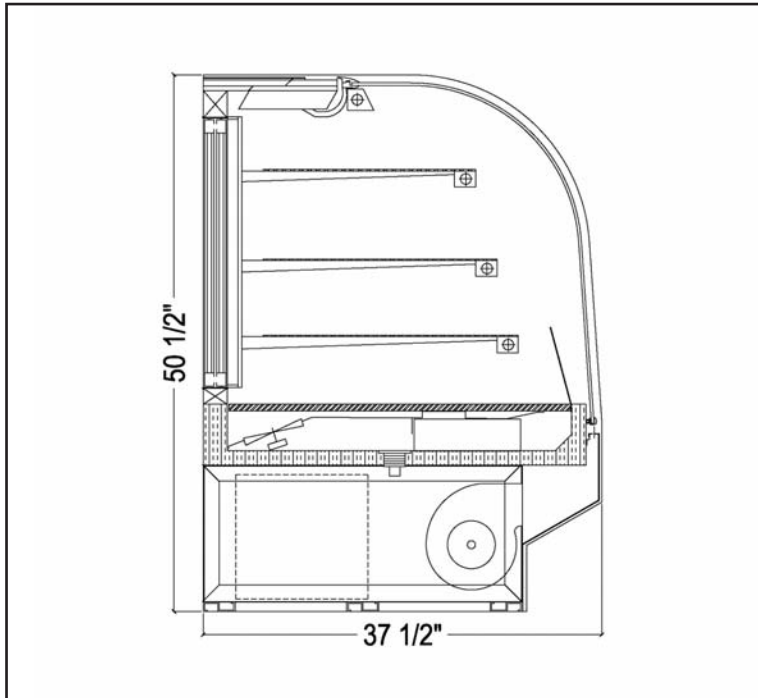

Electrical & Plumbing locations



Refrigerated Case Display 67C9 Listed
Also classified by Underwriters Laboratories Inc.
In Accordance with ANSI/NSF 7-1999 and ANSI/NSF 2-1999

MODEL	L	D	H	COMP HP	VOLT	AMP	NEMA PLUG	WT
SCXB48R	45 7/8	37 1/2	50 1/2	1/3	115V	11.4	5-15P	640
SCXB60R	57 7/8	37 1/2	50 1/2	1/3	115V	11.5	5-15P	740
SCXB72R	69 7/8	37 1/2	50 1/2	1/2	115V	13.9	5-20P	850
SCXB77R	77 5/8	37 1/2	50 1/2	1/2	115V	14.5	5-20P	900
SCXB96R	90 1/4	37 1/2	50 1/2	1/2	115V	15.6	5-20P	1175
SCXB48D	45 7/8	37 1/2	50 1/2		115V	1.2	5-15P	530
SCXB60D	57 7/8	37 1/2	50 1/2		115V	1.2	5-15P	605
SCXB72D	69 7/8	37 1/2	50 1/2		115V	1.2	5-15P	650
SCXB77D	77 5/8	37 1/2	50 1/2		115V	1.8	5-15P	700
SCXB96D	90 1/4	37 1/2	50 1/2		115V	2.2	5-15P	900

The SCXB merchandiser is designed for use in stores where temperature and humidity do not exceed 75 degrees F and 55% R.H. Locate away from direct sunlight, rapid air currents and extreme temperature changes. Any adverse conditions will affect warranty. RPI, in line with its policy to constantly improve its product reserves the right to change materials and specifications without notice.

CALL TOLL FREE: 800-525-3692 (609-714-2330)

FAX: 609-714-2331 www.regalpinnacl.com

220 ROUTE 70, MEDFORD, NJ 08055

RPI REGAL PINNACLE INTEGRATIONS INDUSTRIES, INC.