

CALIFORNIA SLIM SILENT WINE CASE

MODEL # A1CRCAVSLIMSIL

ITEM: _____ QUANTITY: _____

SPECIFICATIONS

Designed for commercial application for refrigeration wine storage with multiple temperature zones within compartments. Unique digital controlled refrigeration system is designed with noise reduction of 41.5 decibels permitting a more comfortable surrounding for placement of unit within restaurant environment.

STANDARD FEATURES

- Solid Wood Door Frame and Grill
Available in Dark Walnut or Light Oak Finish
- Front Glass Insulated Double Glazed Panel
With Door lock
- Internal Low Voltage Lighting
- Static Refrigeration With Finned Evaporator
and Condensate Pan
- 72 Bottle Capacity
- Digital Temperature Control
With Automatic Defrost
- Casters

OPTIONAL FEATURES

- 5-Year Compressor Warranty

DIMENSIONS

Length: 24" x Depth: 20.5" x Height: 81"



Shown with standard features.

WHEN ORDERING, PLEASE SPECIFY:

APPLICATION: _____

WOOD STAIN COLOR: _____

CALIFORNIA SLIM SILENT WINE CASE

MODEL # A1CRCAVSLIMSIL

TOLL FREE: 800-525-3692

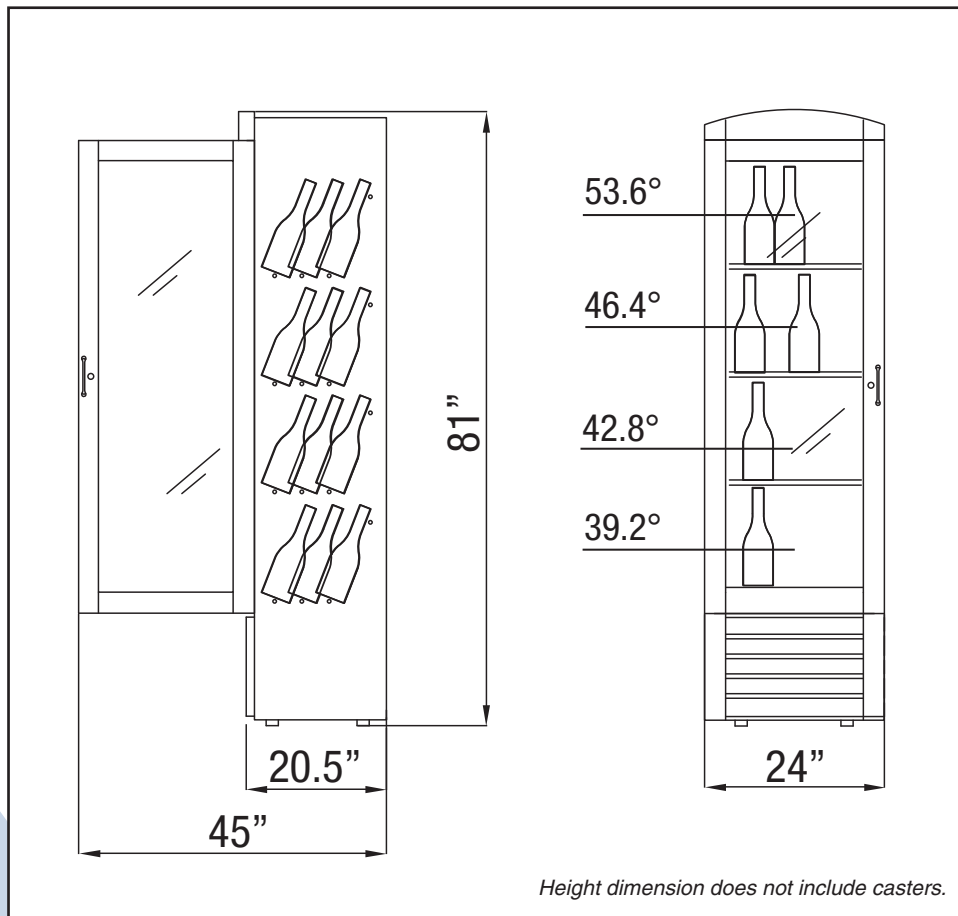

MODEL	L	D	H	VOLT	AMP	NEMA PLUG	WT
A1CRCAVSLIMSIL	24"	20.5"	81"	120V	5.04	5-15P	232

RPI refrigerated cases are designed for use where temperature and humidity do not exceed 75 Degrees Fahrenheit and 55% relative humidity.

Vertical display not recommended for long term wine storage.

RPI, in line with it's policy to continually improve it's products, reserves the right to change materials or specifications without notice.

CALL TOLL FREE: 800-525-3692 (609-714-2330)

FAX: 609-714-2331 www.regalpinncle.com

220 ROUTE 70, MEDFORD, NJ 08055

RPI REGAL
PINNACLE
INTEGRATIONS INDUSTRIES, INC.