

CALIFORNIA SILENT SLIDING DOOR

MODEL # A1CRCAV/SD

ITEM: _____ QUANTITY: _____

SPECIFICATIONS

Designed for commercial application for refrigeration wine storage with multiple temperature zones within compartments. Unique digital controlled refrigeration system is designed with noise reduction of 41.5 decibels permitting a more comfortable surrounding for placement of unit within restaurant environment. Sliding doors allow easy access to wine storage where tight aisles prohibit hinged door application.

STANDARD FEATURES

- Solid Wood Door Frame and Grill
Available in Dark Walnut or Light Oak Finish
- Front Glass Insulated Double Glazed Panel
With Door lock
- Internal Low Voltage Lighting
- Static Refrigeration With Finned Evaporator
and Condensate Pan
- 132 Bottle Capacity
- Digital Temperature Control
With Automatic Defrost
- Casters

OPTIONAL FEATURES

- 5-Year Compressor Warranty

DIMENSIONS

Length: 38" x Depth: 20.5" x Height: 81"

WHEN ORDERING, PLEASE SPECIFY:

APPLICATION: _____

WOOD STAIN COLOR: _____



Shown with standard features.

CALIFORNIA SILENT SLIDING DOOR

MODEL # A1CRCAV/SD

TOLL FREE: 800-525-3692

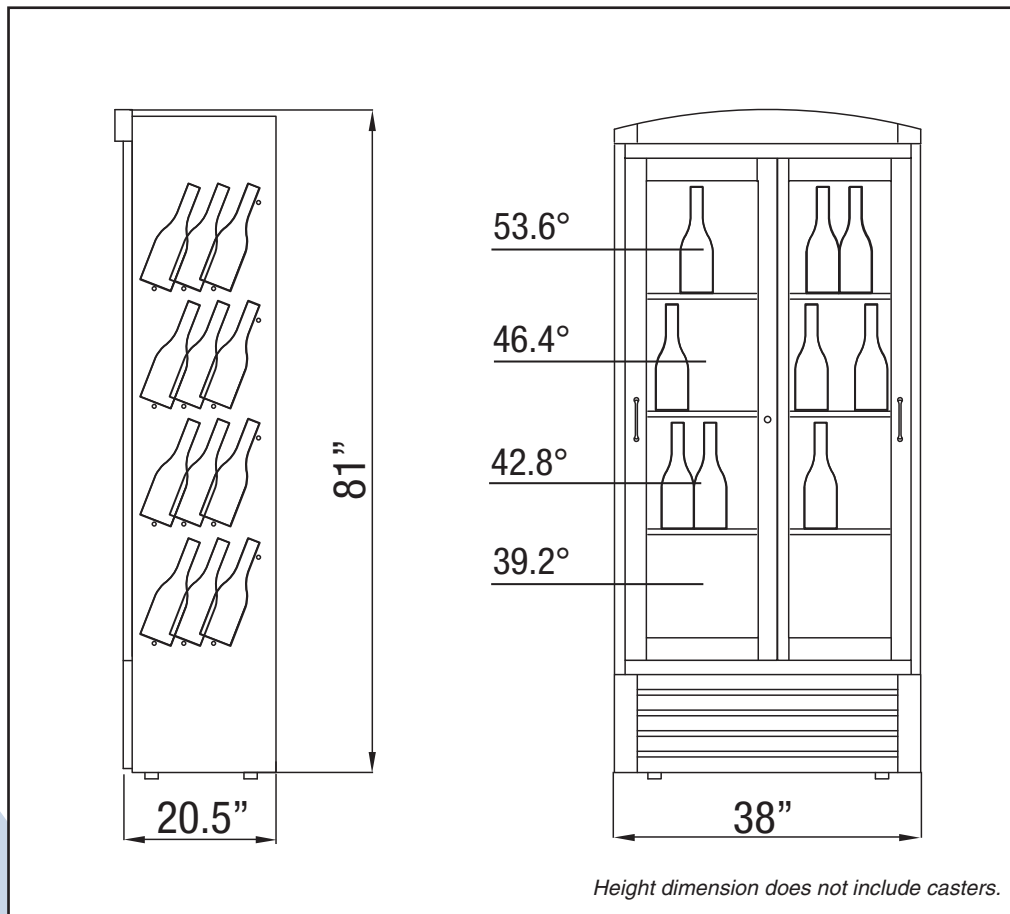

MODEL	L	D	H	VOLT	AMP	NEMA PLUG	WT
A1CRCAV/SD	38"	20.5"	81"	120V	5.04	5-15P	397

RPI refrigerated cases are designed for use where temperature and humidity do not exceed 75 Degrees Fahrenheit and 55% relative humidity.

Vertical display not recommended for long term wine storage.

RPI, in line with it's policy to continually improve it's products, reserves the right to change materials or specifications without notice.

CALL TOLL FREE: 800-525-3692 (609-714-2330)

FAX: 609-714-2331 www.regalpinnacle.com

220 ROUTE 70, MEDFORD, NJ 08055

RPI REGAL
PINNACLE
INTEGRATIONS INDUSTRIES, INC.