

# CALIFORNIA SILENT WINE CASE

MODEL # A1CRCAVSIL

ITEM: \_\_\_\_\_ QUANTITY: \_\_\_\_\_

## SPECIFICATIONS

*Designed for commercial application for refrigeration wine storage with multiple temperature zones within compartments. Unique digital controlled refrigeration system is designed with noise reduction of 41.5 decibels permitting a more comfortable surrounding for placement of unit within the restaurant environment.*

## STANDARD FEATURES

- Solid Wood Door Frame and Grill  
Available in Dark Walnut or Light Oak Finish
- Front Glass Insulated Double Glazed Panel  
With Door lock
- Internal Low Voltage Lighting
- Static Refrigeration With Finned Evaporator  
and Condensate Pan
- 120 Bottle Capacity
- Digital Temperature Control  
With Automatic Defrost
- Casters

## OPTIONAL FEATURES

- A1WR Criss Cross Rack  
(89 Bottle Capacity)
- 5-Year Compressor Warranty

## DIMENSIONS

Length: 33" x Depth: 20.5" x Height: 81"

## WHEN ORDERING, PLEASE SPECIFY:

APPLICATION: \_\_\_\_\_

WOOD STAIN COLOR: \_\_\_\_\_



Shown with standard features.

# CALIFORNIA SILENT WINE CASE

MODEL # A1CRCAVSIL

TOLL FREE: 800-525-3692

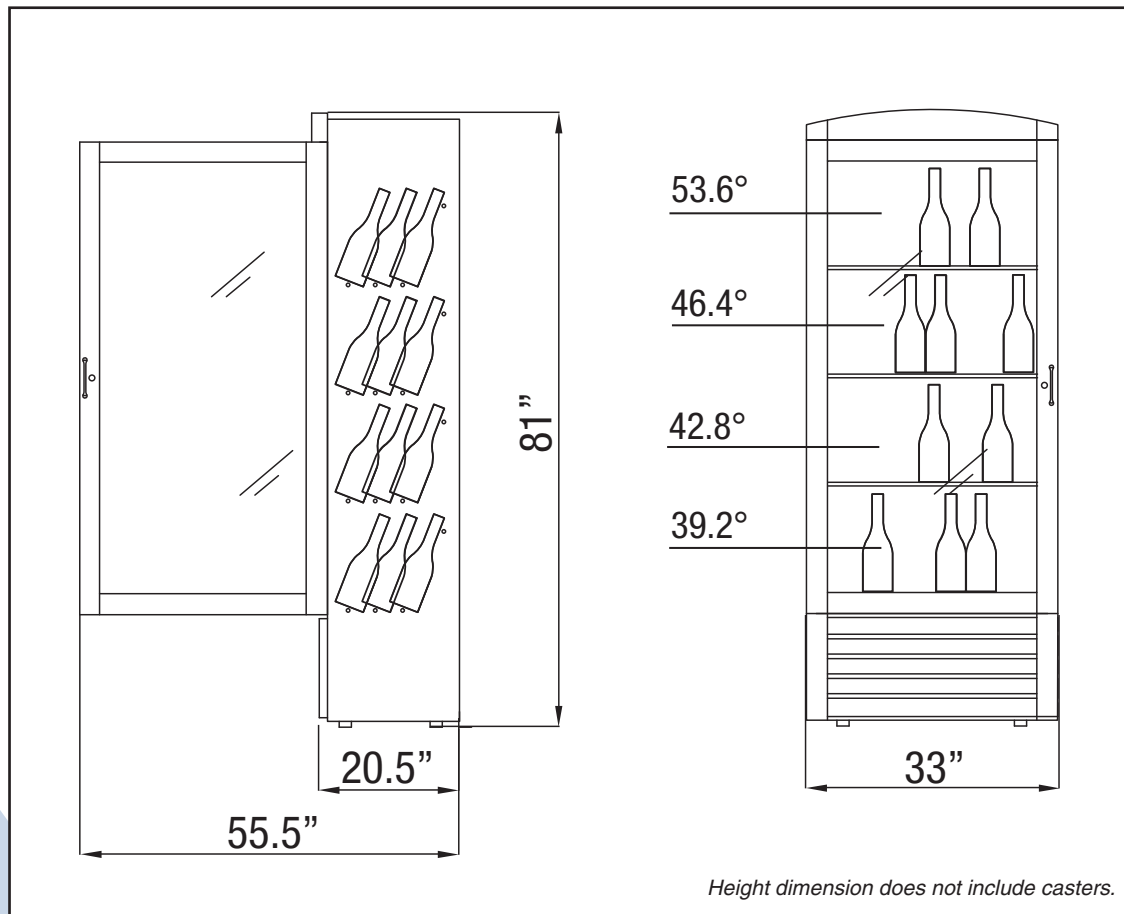

MODEL	L	D	H	VOLT	AMP	NEMA PLUG	WT
A1CRCAVSIL	33"	20.5"	81"	120V	5.04	5-15P	265

RPI refrigerated cases are designed for use where temperature and humidity do not exceed 75 Degrees Fahrenheit and 55% relative humidity.

Vertical display not recommended for long term wine storage.

RPI, in line with it's policy to continually improve it's products, reserves the right to change materials or specifications without notice.

CALL TOLL FREE: 800-525-3692 (609-714-2330)

FAX: 609-714-2331 [www.regalpinnacle.com](http://www.regalpinnacle.com)

220 ROUTE 70, MEDFORD, NJ 08055

