

## MODEL # SCBB

SCBB shown with wire shelves and horizontal laminate inlay.

### SPECIFICATIONS

The SCBB is a Bakery display case with a choice of standard grade plastic laminate exterior ends and fixed curved insulated front glass. Extra deep unit for high volume. Designed to accommodate 18x26 pans.



Available depths:  38"

Available lengths:  60"  80"

NOTE: Cannot fit through a 36" opening.

### STANDARD FEATURES

- Self-Contained Refrigeration
- Standard Grade Laminate Exterior
- Top Canopy Light
- 3 Tempered Glass Shelves with Lights
- White Laminated Deck
- Mirrored Interior Ends
- Mirrored Rear Sliding Doors
- 115V/60/Single Phase
- UL Listed in Accordance with NSF 7
- Built-In Condensate Evaporator
- 134A Refrigerant
- Black Base
- Separate Electrical Outlet on Rear
- Thermometer

### OPTIONAL FEATURES

- Stainless Steel Exterior Finish
- Special Laminates
- Wood Veneers (Unfinished)
- Wood Veneers (Stained & Sealed)
- Miscellaneous Trim
- Promolux Lighting (Low UV)
- Brass Trim and Hardware
- Wire Shelves
  - Brass  White  Black  Chrome
- Casters
- Bullet Feet
- Rear Door Locks
- Rear Fold Down Sani Board
- Top Mount Scale Shelf
- Stainless Steel Deck
- 5 Year Compressor Warranty
- Remote Refrigeration

### WHEN ORDERING, PLEASE SPECIFY:

APPLICATION: \_\_\_\_\_

REFRIGERATION TYPE: \_\_\_\_\_

LAMINATE COLOR: \_\_\_\_\_

# BRENTWOOD BAKERY

TOLL FREE: 800-525-3692

## MODEL # SCBB

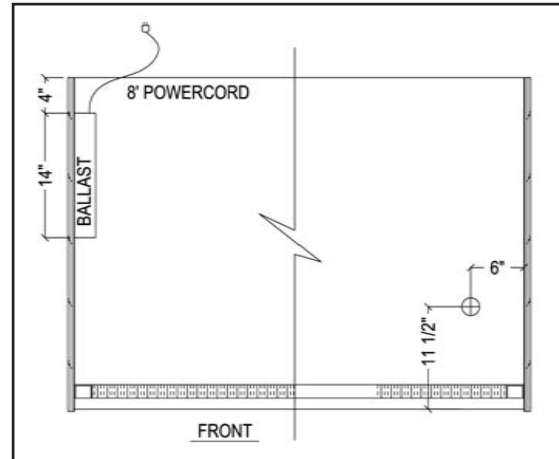
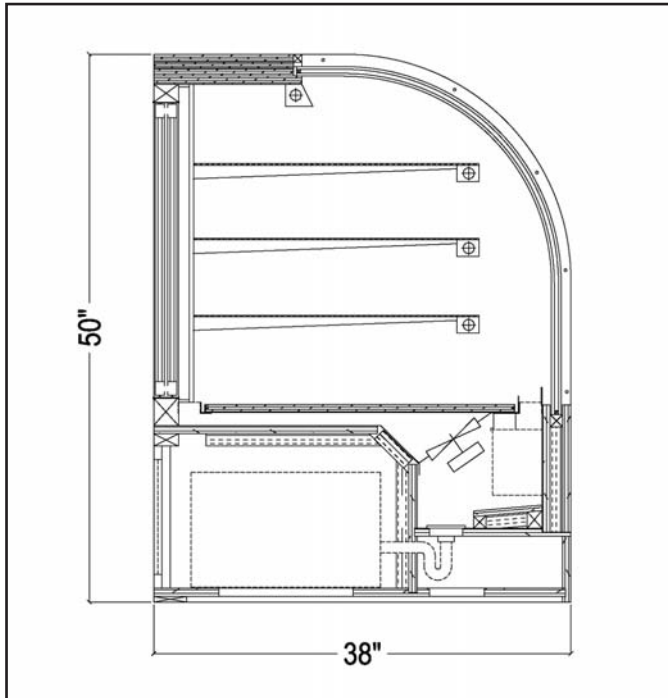

### Electrical & Plumbing locations



Refrigerated Case Display 67C9 Listed  
Also classified by Underwriters Laboratories Inc.  
In Accordance with ANSI/NSF 7-1999 and ANSI/NSF 2-1999

MODEL	L	D	H	COMP HP	VOLT	AMP	NEMA PLUG	18 x 26 PAN	WT
SCBB60R	60	38	50	1/3	115V	12.1	5-20P	12	800
SCBB80R	80	38	50	1/2	115V	16.0	5-20P	16	1000
SCBB60D	60	38	50		115V	1.8	5-15P	12	550
SCBB80D	80	38	50		115V	2.0	5-15P	16	850

The SCBB merchandiser is designed for use in stores where temperature and humidity do not exceed 75 degrees F and 55% R.H. Locate away from direct sunlight, rapid air currents and extreme temperature changes. Any adverse conditions will affect warranty. RPI in line with its policy to continually improve its product reserves the right to change materials and specifications without notice. Electrical outlet on rear of case is designed for 2 amps or less.

CALL TOLL FREE: 800-525-3692 (609-714-2330)

FAX: 609-714-2331 [www.regalpinnacle.com](http://www.regalpinnacle.com)

220 ROUTE 70, MEDFORD, NJ 08055

**RPI** REGAL PINNACLE INTEGRATIONS INDUSTRIES, INC.