

## MODEL # SCBC

SCBC - Shown with optional brass trim and front merchandising compartment.

### SPECIFICATIONS

The SCBC is a refrigerated Confectionary display case with a choice of standard grade plastic laminate exterior ends and fixed curved front glass.



Available depths:  30"

Available lengths:  48"  60"  72"  96"

### STANDARD FEATURES

- Standard Grade Laminate Exterior
- Top Canopy Light
- 3 Tempered Glass Shelves
- White Laminated Deck
- Mirrored Interior Ends
- Mirrored Rear Sliding Doors
- 115V/60/Single Phase
- Built-In Condensate Evaporator
- 134A Refrigerant
- Black Base
- Limited Base Storage
- Thermometer

### OPTIONAL FEATURES

- Stainless Steel Exterior Finish
- Special Laminates
- Wood Veneers (Unfinished)
- Wood Veneers (Stained & Sealed)
- Miscellaneous Trim
- Promolux Lighting (Low UV)
- Lights Under Shelves
- Front Glass Locks (Lower Only)
- Rear Door Locks
- Brass Trim and Hardware
- Wire Shelves
  - Brass  White  Black  Chrome
- Casters
- Bullet Feet
- 5 Year Compressor Warranty
- Remote Refrigeration

### WHEN ORDERING, PLEASE SPECIFY:

APPLICATION: \_\_\_\_\_

REFRIGERATION TYPE: \_\_\_\_\_

LAMINATE COLOR: \_\_\_\_\_

# BRADFORD CANDY

TOLL FREE: 800-525-3692

## MODEL # SCBC

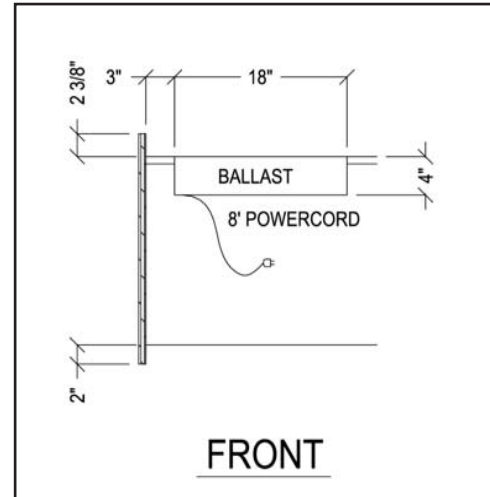
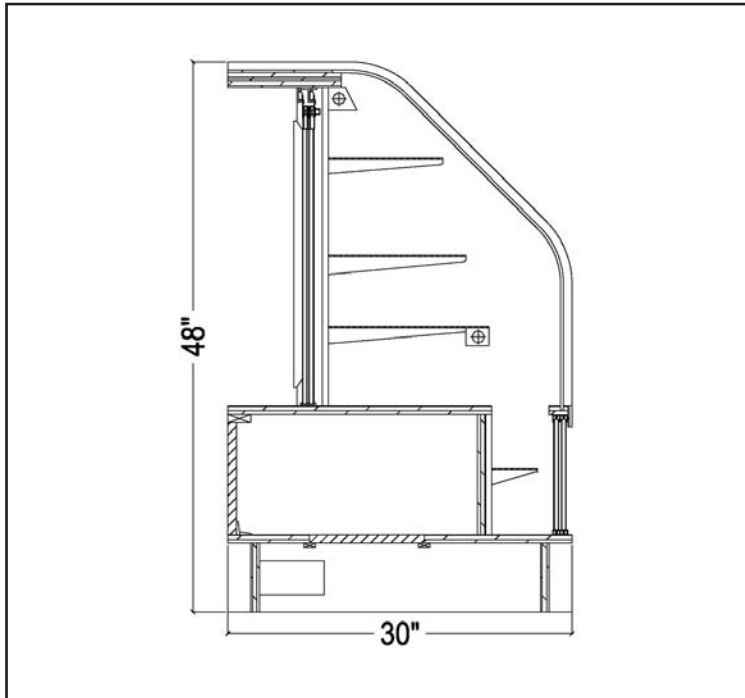

### Electrical & Plumbing locations



Refrigerated Case Display 67C9 Listed  
 Also classified by Underwriters Laboratories Inc.  
 In Accordance with ANSI/NSF 7-1999 and ANSI/NSF 2-1999

MODEL	L	D	H	COMP HP	VOLT	AMP	NEMA PLUG	WT
SCBC48R	48	30	48	1/4	115V	8.6	5-15P	475
SCBC60R	60	30	48	1/4	115V	8.6	5-15P	560
SCBC72R	72	30	48	1/4	115V	8.9	5-15P	725
SCBC96R	96	30	48	1/4	115V	9.8	5-15P	850
SCBC48D	48	30	48		115V	2.5	5-15P	300
SCBC60D	60	30	48		115V	2.5	5-15P	325
SCBC72D	72	30	48		115V	2.8	5-15P	350
SCBC96D	96	30	48		115V	3.0	5-15P	475

The SCBC merchandiser is designed for use in stores where temperature and humidity do not exceed 75 degrees F and 55% R. H. Locate away from direct sunlight, rapid air currents and extreme temperature changes. Confectionary cases are designed to refrigerate at 60 degrees to 67 degrees. Any adverse conditions will affect warranty.

RPI in line with it's policy to continually improve it's product reserves the right to change materials and specifications without notice.

CALL TOLL FREE: 800-525-3692 (609-714-2330)

FAX: 609-714-2331 [www.regalpinnacl.com](http://www.regalpinnacl.com)

220 ROUTE 70, MEDFORD, NJ 08055

