



Model 149



The Prince Castle Pancake Batter Dispenser allows you to prepare pancakes to your specifications. Choose either a 3, 4, 5 or 6-inch diameter by simply adjusting a screw or rotating the slide block. Every pancake you make will be uniform in size and appealing to your customers. The model 149 helps you save money by maximizing your production and minimizing waste.

A built-in stand and easy-press lever work together to allow you to dispense batter right on the griddle...no more pouring, no more mess. A contoured Bakelite handle resists hot temperatures and guarantees a sturdy grip for making large quantities of pancakes quickly and comfortably.

STANDARD FEATURES

- n Portion control for dispensing consistent product amounts.
- n Adjustable for any size pancake.
- n Convenient lever design for easy dispensing.
- n Built-in legs—no need for a stand.
- n Stainless steel construction.
- n Finger-formed Bakelite handle.
- n Easy to clean.
- n Holds up to 48 oz. (1.36 kg).

OPTIONS

Part No.	Description
----------	-------------

356	Pancake Turner for heavy-duty flipping
-----	--

Model 356



- n Flips pancakes up to 6" in diameter.
- n Easy grip handle.
- n Helps eliminate sticking.
- n Durable stainless steel finish for easy clean-up.

149 PANCAKE BATTER DISPENSER

PRINCE CASTLE INC. 
WORLDWIDE

SPECIFICATIONS

DIMENSIONS

MODEL NUMBER	LENGTH IN. (CM)	HEIGHT IN. (CM)	DEPTH IN. (CM)	SHIPPING WT. LB. (KG.)
149	13 ³ / ₈ (33.97)	10 ⁵ / ₈ (26.98)	7 (17.78)	6 (2.72)

ORDERING INFORMATION

MODEL	DESCRIPTION
149	Pancake Batter Dispenser
142-45	Replacement Parts Kit

ACCESSORIES

MODEL	DESCRIPTION
356	Pancake Turner

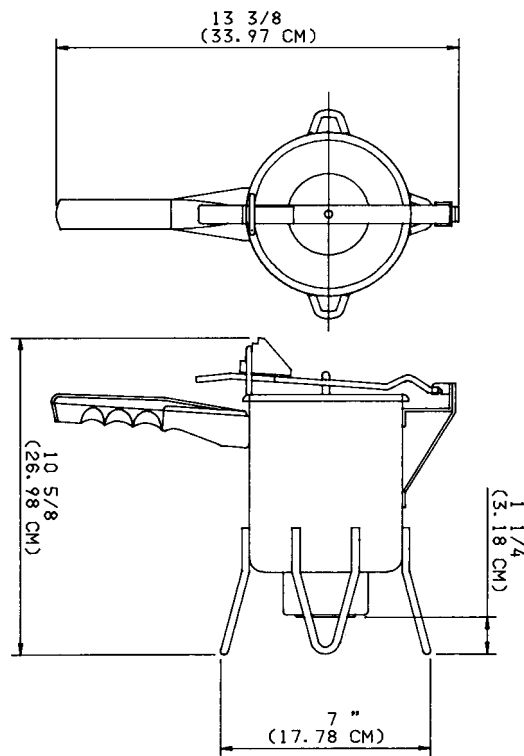

*Designs and specifications are subject to change without notice.



PANCAKE BATTER DISPENSER

149