



Model shown KU072SC with optional top and casters.

Features & Benefits

Kairak's KU Series full size undercounter refrigerator models are designed for use with most applications, combining the advantages of modular flexibility with ease of maintenance. They are built to perform, their heavy duty construction, quality components and innovative design are all intended to provide a high quality, durable product you can depend on.

Our undercounter models feature a door or drawer option. We've engineered our models with a drop-in feature that allows you to easily convert doors into two 6" deep drawers or three 4" deep drawers. Making them ideal for any work area reorganization. Additionally, we meet the needs of today's food service operators by providing assured product holding temperatures, maximized storage capacity and features that assist with HACCP compliance, making them an excellent choice and value.

Standard Features

- » Stainless Steel Exterior & interior
- » Microprocessor Control System
- » Balanced, Self-Contained refrigeration System Using R-404a
- » Front-Breathing Design for "Zero-Clearance" Installation
- » Non-Electric Automatic Condensate Evaporator
- » Condenser Filter
- » Off-Cycle Evaporator Defrost
- » Controllable Anti-Condensate Perimeter Heaters
- » Metal Door Handle with Gasket Guard
- » Self-Closing, Doors With Stay Open Feature
- » Field Re-Hingeable Door(s)
- » Standard Door Hinging:
KU044SC = Right
KU072SC = Left/Right
KU100SC = Left/Left/Right
(other hingsings available)
- » Two Chrome Plated Shelves Per Door (factory installed)
- » Magnetic Snap-In Door Gaskets
- » Thermostatic Expansion Valve Metering Device
- » Side, Front & Rear Access Panel for Ease of Service & Maintenance
- » 9' Cord and Plug Attached
- » 6" Legs on Adjustable Channel Moving System
- » One Year Parts and Labor Warranty
- » Five Year Compressor Warranty

Models

KU044SC	1 Door
KU072SC	2 Door
KU100SC	3 Door

Options & Accessories

- » Two (2) Drawers in Lieu of One or More Door(s) (accommodates 6" deep pans)
- » Three (3) Drawers in Lieu of One or More Door(s) (accommodates 4" deep pans)
- » Flat Stainless Steel Top with Bullnose Front
- » Stainless Steel Top with 4" High Backsplash
- » Stainless Steel Top with Drip Guard (marine) Edge
- » Cabinet Length Extension Sections, Available in 3", 6", 12" and 15" Sizes
- » No. 1 Type Tray Slides to Accommodate either (1) 18" x 26" or (2) 14" x 18" Sheet Pans, Adjustable to 2" O.C.
- » Universal Type Tray Slides to Accommodate either (1) 18" x 26". (2) 12" x 20" or (2) 14" x 18" Sheet Pans, Adjustable to 4" O.C.
- » Additional Chrome Plated Shelves
- » Stainless Steel Shelves in Lieu of Standard Chrome Plated
- » Export Voltage
- » System Relocated to Left
- » Door Lock(s)
- » Set of 4-5/8" or 6" High Casters
- » Remote Application
- » Glycol Remote Application



KU / 5-18-2010
Made in the U.S.A.

Kairak Full Size Undercounter models are
ENERGY STAR® listed for efficient operation!



Product Details

Construction, Hardware and Insulation

Cabinet exterior front, sides, one-piece louver assembly and doors are constructed of stainless steel. Cabinet interior and door liners are constructed of heavy gauge galvanized steel. A set of adjustable 6" high stainless steel legs are included as standard.

Doors are equipped with a gasket protecting metal door pan. A metal door handle with gasket guard is standard on all units.

Easily removable for cleaning, vinyl magnetic door gasket assures tight door seal. Anti condensate heaters are located behind each door opening.

Both the cabinet and door(s) are insulated with an average of 2" thick high density non-CFC, foamed in place polyurethane.

Controller

The easy to use water resistant microprocessor control system is supplied standard. Unit is NAFEM Data Protocol communication (NDP) ready. Optional hardware required to be NDP compliant. Third party software required for network connection. It includes a 2-Digit LED Display, Fahrenheit or Celsius Temperature Scale Display Capability, and a RS485 data port. In addition it includes audio/visual alarms for: Hi/Lo Cabinet Temperature, Clean Condenser, Evaporator Coil and Discharge Line Sensor Failures, and Power Supply Interruption.

Interior

Standard interior arrangements include two (2) chrome plated wire shelves per door, mounted on shelf pins. Recommended load limit per shelf should not exceed 225 lbs. Optional tray slides may be purchased in combination with, or in lieu of these. Both standard and optional interior arrangements are completely installed at the factory.

Refrigeration System

The self-contained, balanced refrigeration system using R-404a refrigerant features a hot gas evaporator defrost, thermostatic expansion valve, air-cooled hermetic compressor, plenum effect blower coil, large, high humidity evaporator coil located outside the food zone. A 9' cord and plug is provided. Standard operating temperature is 34 to 38°F.

Warranties

Both a one year parts and labor warranty and a five year compressor warranty (self-contained models only) are provided standard.

Product Specifications

DIMENSIONAL DATA	KU044SC	KU072SC	KU100SC
Net Capacity Cu. Ft.	9.8 (277 cu l)	20.0 (566 cu l)	30.1 (852 cu l)
Length Overall in.	44 (111.7 cm)	71 3/4 (182.2 cm)	100 (254 cm)
Depth Cabinet Only in.	31 1/4 (79.4 cm)	31 1/4 (79.4 cm)	31 1/4 (79.4 cm)
Depth with Door Open 90°	58 13/18 (149.4 cm)	58 13/18 (149.4 cm)	58 13/18 (149.4 cm)
Clear Door Height in.	20 1/2 (52.1 cm)	20 1/2 (52.1 cm)	20 1/2 (52.1 cm)
Clear Door Width in.	23 (58.4 cm)	23 (58.4 cm)	23 (58.4 cm)
Depth Overall in.	34 (86.4 cm)	34 (86.4 cm)	34 (86.4 cm)
Height Overall on 6" legs in. *	34 (86.4 cm)	34 (86.4 cm)	34 (86.4 cm)
Height Overall on 6" legs in. **	33 7/10 (85.6 cm)	33 7/10 (85.6 cm)	33 7/10 (85.6 cm)
Number of Shelves	2	4	6
Shelf Area sq.ft	8.5 (.8 sq m)	18.2 (1.7 sq m)	28.3 (2.6 sq m)

REFRIGERATION DATA

	R-404a	R-404a	R-404a
Refrigerant	R-404a	R-404a	R-404a
BTU/HR - HP***	2440 (1/3 HP)	2440 (1/3 HP)	2440 (1/3 HP)

ELECTRICAL DATA

	115/60/1	115/60/1	115/60/1
Voltage	115/60/1	115/60/1	115/60/1
Cord & Plug	NEMA 5-15P	NEMA 5-15P	NEMA 5-15P
Full Load Amperes	6.3	6.3	6.3

WEIGHT DATA

NOTE: Figures in parentheses reflect metric equivalents

NOTE: An optional stainless steel worktop is required on full size undercounter models being used to support equipment weighing in excess of 100 lbs. or producing heat in excess of 140°F to the top surface

NOTE: When ordering, please specify: Voltage, Hinging, Options and any additional warranties.

Continued product development may necessitate specification changes without notice

* Height shown with optional top
 ** Height shown without optional top
 *** Based on a 90 degree F ambient and 20 degree F evaporator.

Full Size Undercounters

KU044SC Plan View

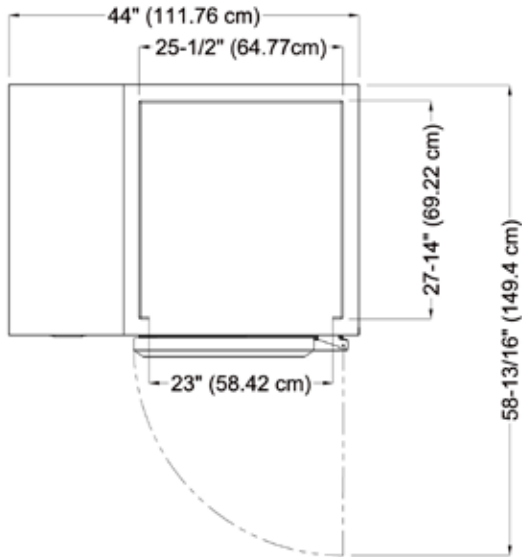

KU072SC Plan View

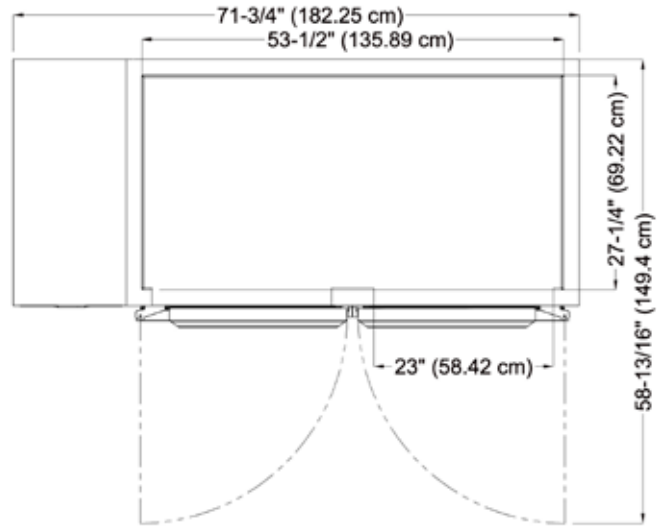

KU100SC Plan View

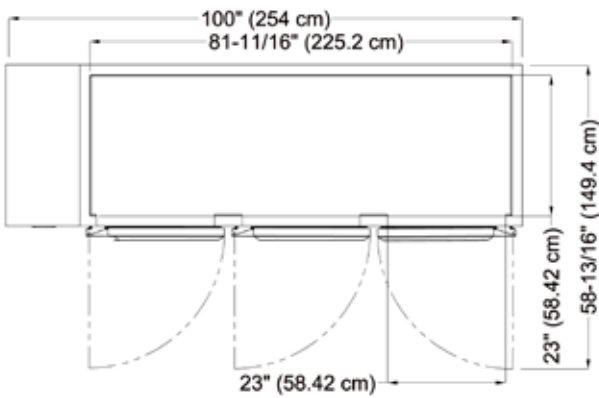

Section View

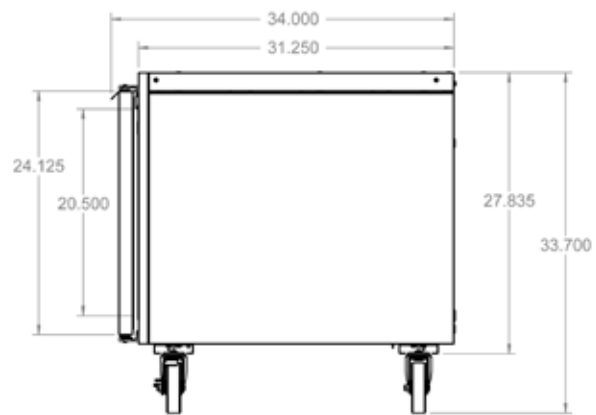

Full Size Undercounters

KU044SC Elevation View

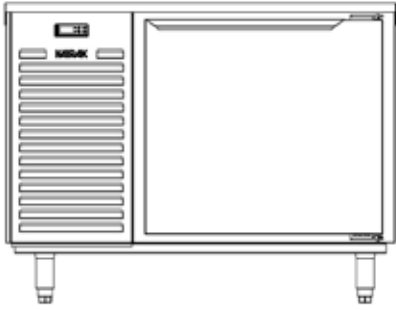

KU072SC Elevation View

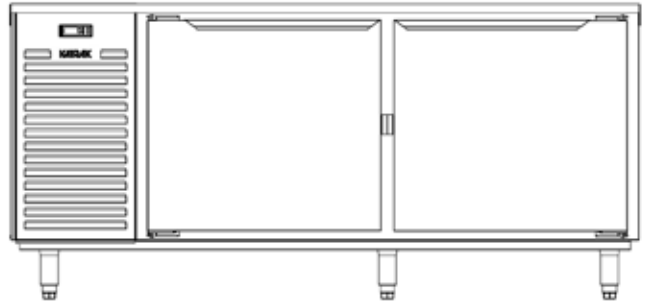

KU100SC Elevation View

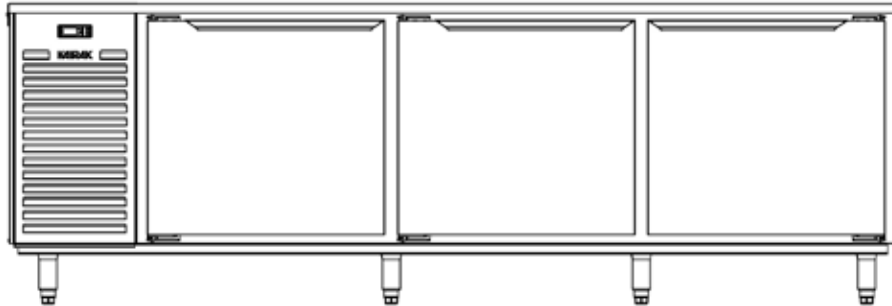

Comments: