

Model KMR-2FN

Models

MINI-RAK2 MODEL

Product Details

SPECIFICATIONS

Kairak offers an extensive line of remote refrigeration systems for various applications and environmental conditions. Remote systems provide great benefits to any operation by removing the heat and noise of multiple compressors from the retail area or kitchen space thus reducing air conditioning and operating costs.

REFRIGERATION UNITS

Air-cooled compressors are hermetic/glacier scroll type (Copeland). Each unit is equipped with high-low pressure control, liquid drier, sight glass & head pressure control.

All compressor units are new factory assembled to operate with refrigerant specified in the engineering summary sheet. Refrigerant R-404a is used on all commercial temperature units and low temperature units.

PRE-PIPING

All refrigerant lines are extended to the right side of the package in a neat and orderly manner inside the refrigeration rack. Suction line for medium and low temperature units must be insulated with Armaflex (3/4" thick).

All tubing is securely supported and anchored with clamps.

Silver Solder and/or sil-fos used for all refrigerant piping. Soft solder is not acceptable.

All piping is pressure tested with nitrogen at 100 PSI.

Control Panel

The package has a factory mounted and pre-wired control panel complete with main disconnect breaker switch, compressor circuit breakers, fuses, contractors and time clocks wired for single point connection.

Electrical contractor shall provide and install main power lines to panel and provide wire harness wiring for control and defrost heater between the defrost clock and the refrigerant fixtures, if necessary. All in accordance with the wiring diagram and local codes and shall ensure that main power feed enters refrigeration equipment through same pitch pocket as the refrigeration lines.

EVAPORATOR COIL

Evaporator coils are direct expansion type fabricated of copper tubes with aluminum fins. All evaporator coils are provided with solenoid valve, thermostatic expansion valve and thermostat. Piped and wired ready for final connection by the electrical and refrigeration contractors.

WARRANTY

Five (5) Year Compressor, Ninety (90) Day Parts and Labor Provided Standard.

Features

- » Removable sectional condenser, multi-circuited with rifled tube slotted finned and is designed for 15° FTD.
- » Condenser fan motors mounted on side of the enclosure.
- » Choice of scroll compressors, semi-hermetic and hermetic.
- » Weather Protected Enclosure
- » Galvanized Steel Frame, Enclosure and Panels.
- » Frame is Pre-assembled, Welded, Cleaned and Epoxy Coated.
- » Enclosure has removable louvers.

Options

- » Sectional condensers can be coated to prolong condenser life against corrosion
- » Liquid Line Solenoid
- » Up to 3.5 HP Total "Med Temp" @ 25° Suction
- » Up to 7.5 HP Total "Low Temp" @ -20° Suction
- » Stainless steel enclosure with painted base
- » Maximum total compressor HP will be determined by the compressor(s) used.



Remote Refrigeration Systems (KMR-2FN)

KMR-2FN Model

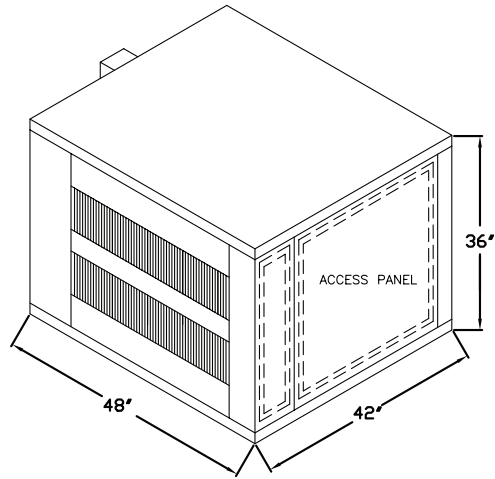

Product Specifications

DIMENSIONAL DATA	KMR-2FN
Length - in.	42
Depth - in.	48
Height in.	36

Electrical & refrigeration data varies on product configuration.

Consult factory for product data.

Specification subject to change without prior notice.