



Model shown KE036SC (2 drawer, 2 pan capacity)

Product Details**Specifications**

Kairak's Equipment Stand offering is available in Standard lengths ranging from 36-110 inches. Two, four, six and eight drawer models. Accommodates 6" deep pans.

Top

16-Gauge Stainless Steel with Marine Edge.

Body

Cabinet exterior, front and sides, louver assembly and drawers are constructed of stainless steel. Exterior back and bottom are constructed of heavy gauge galvanized steel. Cabinet interior walls are constructed of stainless steel. Top and bottom and constructed of stainless steel. A set of 4" high casters are included as standard. Vinyl magnetic snap-in drawer gasket assures tight drawer seal and easily removable for cleaning. Anti-condensate heaters are located behind each drawer opening.

Insulation

Both the cabinet and drawers are insulated with 2" thick high density non-CFC, foamed in place polyurethane.

Drawers

Each heavy-duty drawer is designed to accommodate 12"x20", 6" inch deep pans. The drawers themselves are constructed using stainless steel drawer slides and stainless steel drawer rollers. Includes both a self-closing and stay open feature. Each drawer is rated at 75 pounds.

Refrigeration

Self-contained, balanced refrigeration system using R-404a refrigerant comes standard with left hand refrigeration placement. It features and off-cycle defrost, capillary tube, air-cooled hermetic compressor, and an automatic condensate evaporator. A NEMA 5-15P plug and 9' cord and retainer is provided. Cabinet operating temperature is 34° to 38°F. Dedicated rear mount evaporator and design redistributes air through each drawer section.

Microprocessor

Our easy to use water resistant microprocessor control system is supplied standard. In addition, it includes audio/visual alarms for: hi/lo cabinet temperature, clean condenser, evaporator coil, discharge line sensor failures, and power supply interruption.

Warranty

One (1) Year Parts & Labor
Five (5) Year Compressor

Models

KE036SC	36" Length	2 Drawer	2 Pan
KE048SC	48" Length	2 Drawer	4 Pan
KE060SC	60" Length	2 Drawer	6 Pan
KE065SC	65" Length	4 Drawer	6 Pan
KE072SC	72" Length	4 Drawer	8 Pan
KE084SC	84" Length	4 Drawer	8 Pan
KE096SC	96" Length	6 Drawer	12 Pan
KE110SC	110" Length	6 Drawer	12 Pan

Features & Benefits

- » Stainless steel exterior & interior
- » Stainless steel top with drip guard (marine) edge
- » Microprocessor control system
- » Balanced, self-contained refrigeration system using R-404a
- » Front-breathing design for "zero-clearance" installation
- » Non-electric automatic condensate evaporator
- » Condenser filter
- » Off-cycle evaporator defrost
- » Controllable anti-condensate drawer perimeter heaters
- » Full length drawer handle with gasket guard
- » Magnetic Snap-in Drawer Gaskets
- » Drawers to accommodate 12"x20", 6" pans (by others)
- » Self-closing drawers with stay open feature
- » Stainless steel drawer slide
- » Stainless steel drawer rollers
- » Side, front & rear access panel for ease of service & maintenance
- » NEMA 5-15P plug with 9' cord & cord retainer
- » 4" High casters mounted in adjustable channel system

Optional Features

- » Set of 6" high stainless steel legs in lieu of casters
- » 6" Cabinet length extension
- » Stainless steel exterior finished back
- » Export (International) voltage
- » Remote applications
- » Refrigeration Relocated to left



KE / 5-18-2010
Made in the U.S.A.

Product Specifications

DIMENSIONAL DATA	KE036SC	KE048SC	KE060SC	KE065SC	KE072SC	KE084SC	KE096SC	KE110SC
Length in.	36	48	60	65	72	84	96	110
Depth Over Handle in.	34	34	34	34	34	34	34	34
Height on 4" casters in.	26	26	26	26	26	26	26	26
Drawers per Cabinet	2	2	2	4	4	4	6	6
Pan Capacity 12"x20"x6" in.	2	4	6	6	8	8	12	12
Max. Top Load Capacity lbs.	625	625	1200	1200	1200	1500	1500	1500

ELECTRICAL DATA

Voltage	115/60/1	115/60/1	115/60/1	115/60/1	115/60/1	115/60/1	115/60/1	115/60/1
Full Load Amperes	6.7	6.7	6.7	6.7	6.7	6.7	12	12
NEMA	5-15P	5-15P	5-15P	5-15P	5-15P	5-15P	5-15P	5-15P

REFRIGERATION DATA

Refrigerant	R-404a	R-404a	R-404a	R-404a	R-404a	R-404a	R-404a	R-404a
H.P.	1/3	1/3	1/3	1/3	1/3	1/3	1/2	1/2

SHIPPING DATA

Shipping Weight	410	430	475	510	555	655	760	845
-----------------	-----	-----	-----	-----	-----	-----	-----	-----

Comments:

Equipment Stands

KE036SC

Plan and Elevation View

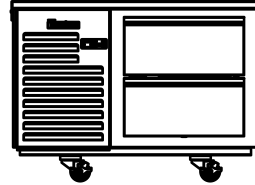
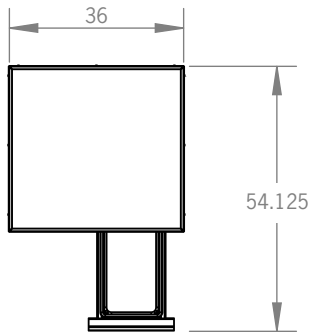

KE048SC

Plan and Elevation View

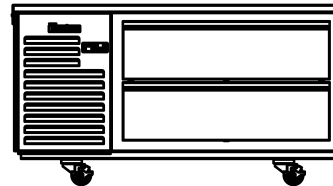
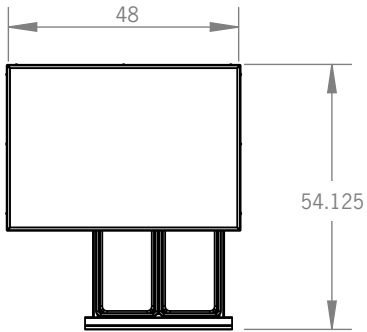

KE060SC

Plan and Elevation View

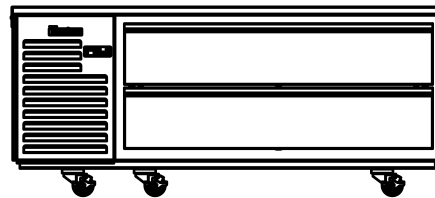
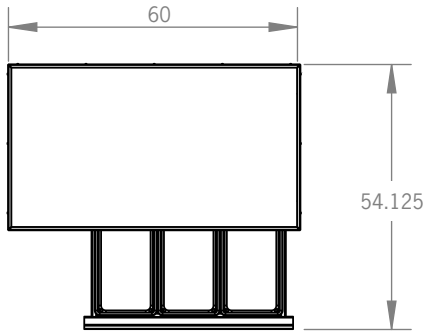

**All Models
Section View**

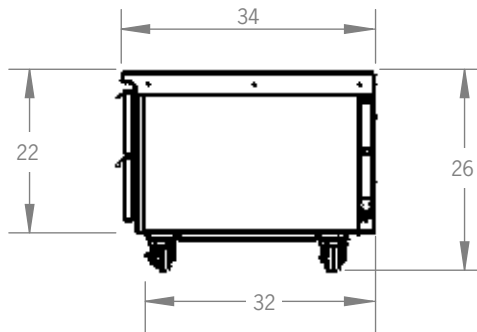

Equipment Stands

KE065SC
Plan and Elevation View

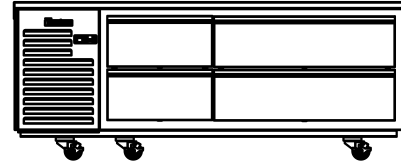
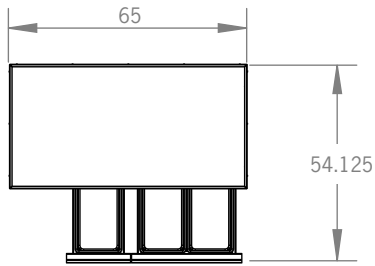

KE072SC
Plan and Elevation View

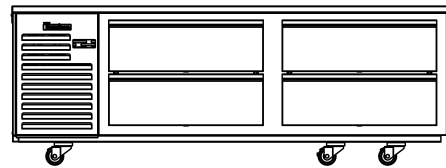
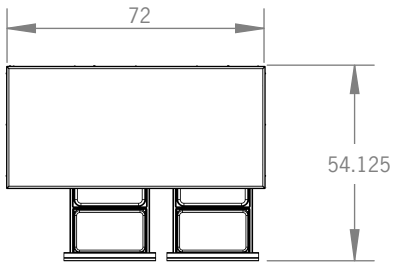

KE084SC
Plan and Elevation View

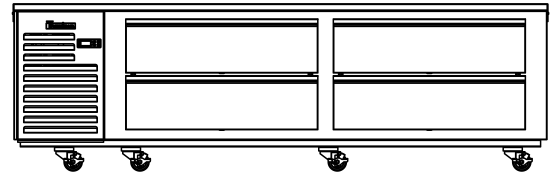
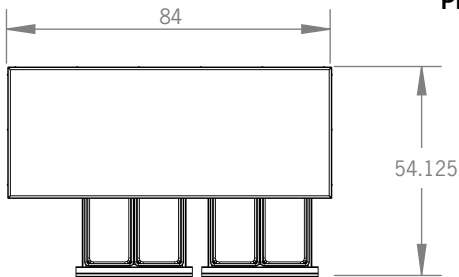

All Models
Section View

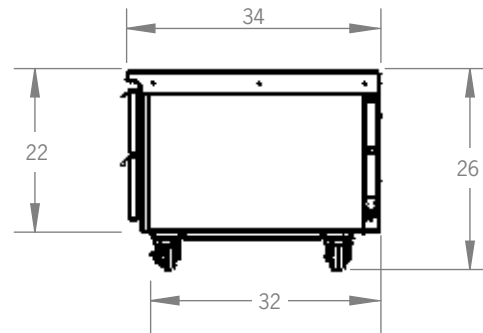

Equipment Stands

KE096SC

Plan and Elevation View

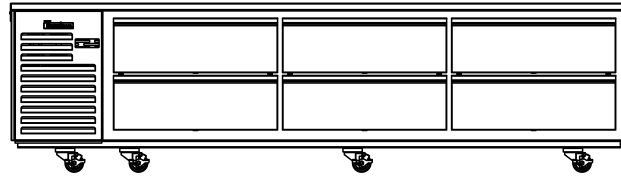
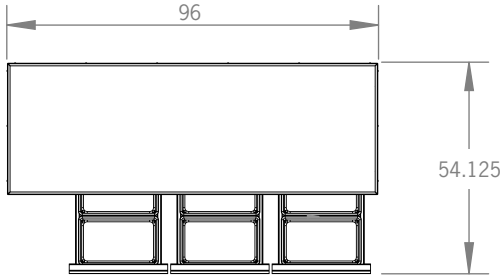

KE110SC

Plan and Elevation View

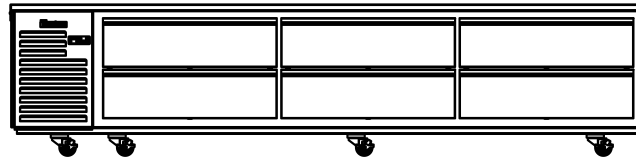
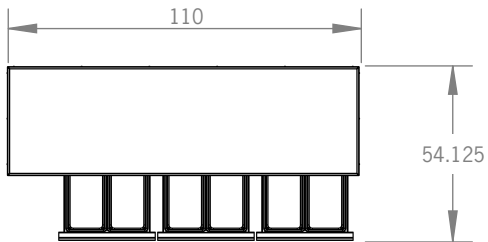

**All Models
Section View**

