

HOBART701 S Ridge Avenue, Troy, OH 45374
1-888-4HOBART • www.hobartcorp.com**HBR301-1 BENCH/RECEIVING
DIGITAL SCALE****HOBART****STANDARD FEATURES**

- Easy-to-Read Display
- Legal for Trade
- Energy Saver Setting - Set Shutoff Time to Extend Battery Life
- Low Battery Indicator
- Check Weighing
- Batch Weighing
- Over and Under Weighing
- Tilt and Rotatable Display for Easy Viewing
- Toggle Between (Lb./Kg.)
- Stainless Steel Platter
- Tare Indicator
- One Touch and Reset Tare
- Zero Key
- Stable Weight Indicator
- Net/Gross Weighing
- Automatic Zero Tracking
- AC/DC Adapter
- Battery Power Supply (6) D Cell
- Leveling Leg Set
- Leveling Indicator

ACCESSORIES

- HBR-301 Stand, Moveable Cart with Swivel Casters, Rear Locks
- Batteries Sold Separately

MODELS

- HBR301-1 300 lb. capacity (150 kg)
- HBR301-60 60 lb./960 oz. capacity (30 kg)

Specifications, Details and Dimensions on Reverse Side.

**HBR301-1 BENCH/RECEIVING DIGITAL SCALE**

HBR301-1 BENCH/RECEIVING DIGITAL SCALE



701 S Ridge Avenue, Troy, OH 45374
1-888-4HOBART • www.hobartcorp.com

SPECIFICATIONS

- **DIMENSIONS: Shipping:** 33"L x 19"W x 14"H;
Assembled: 29.5"H x 25"L x 16.5"W
- **PLATTER:** 15⁷/₈"W x 19⁷/₈"L stainless platter
- **DISPLAY:** 90 degree rotating LCD display

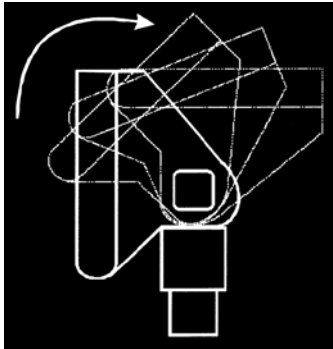

ROTATING DISPLAY

- **CHARACTERS AND SIZE:** .05" (12 mm) (W) x 0.9" (23 mm) (GH), 5 digits
- **SHIPPING WEIGHT:** 37 lbs.
- **POWER SUPPLY:** 120/60/1 using AC adaptor (included as standard) or 9V DC – six "D" batteries (must be purchased separately). Battery life 600 continuous hours use (when using alkaline batteries)

- **OPERATING TEMP:** 23°F to 95°F (-5°C to 35°C)
- **OPERATING HUMIDITY:** 25% to 85% RH
- **WATERPROOF CLASSIFICATION:** Complies with NEMA 4 (washdown) when the AC jack is unplugged or plugged with a watertight seal

SELLING FEATURES

- The HBR301 can be used on the bench, floor or moveable cart.
- Receiving scales prevent costly mistakes by accurately check weighing.
- The HBR301 can be used as a bench portion control scale to keep food costs in line.
- The scale tare feature can be set for package or bowl weight to protect profits.
- Easy to clean and sanitize.

Model	Capacity (lb.)	Capacity (oz.)	Capacity (kg)
HBR301-1	*300 x 0.1	4800 x 2	150 x 0.05
HBR301-60	60 x 0.02	*960 x 0.5	30 x 0.01

*Indicates as configured from factory.

DETAILS AND DIMENSIONS

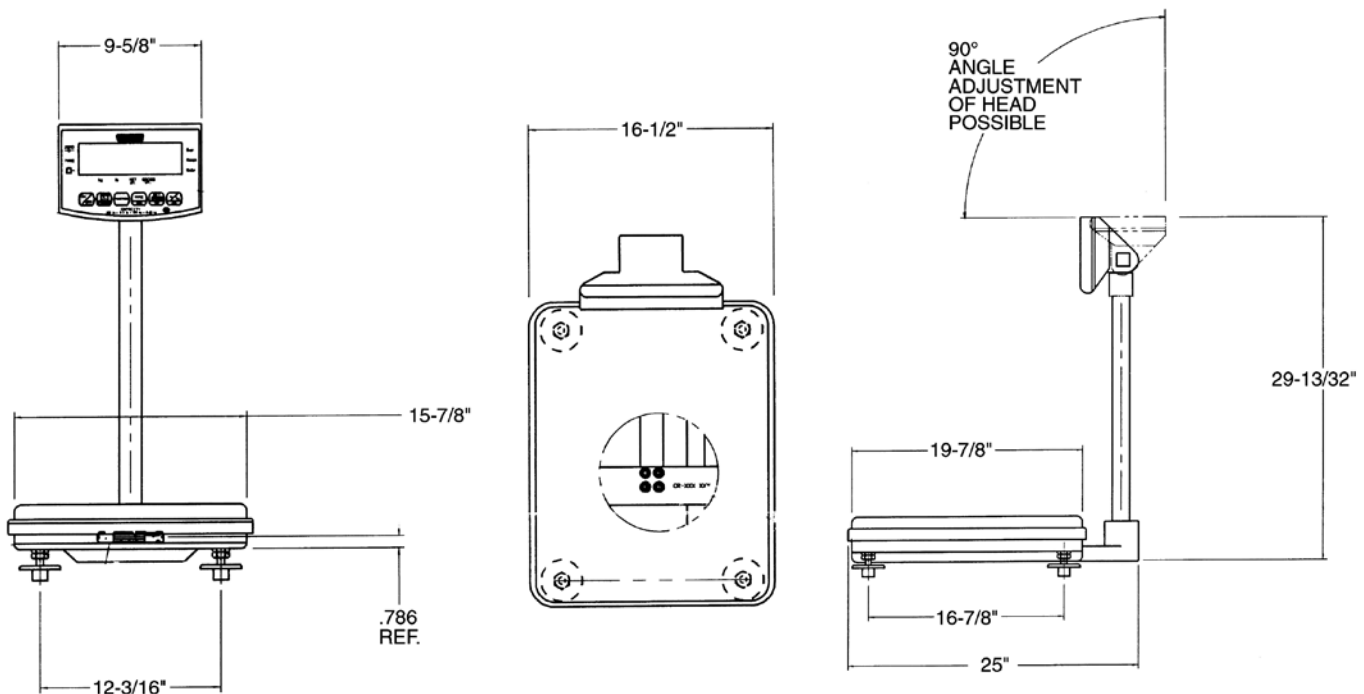

As continued product improvement is a policy of Hobart, specifications are subject to change without notice.