

HOBART701 S Ridge Avenue, Troy, OH 45374
1-888-4HOBART • www.hobartcorp.com**HSL180
SPIRAL MIXER****HOBART****STANDARD FEATURES**

- Fixed Bowl
- Stainless Steel Wireform Bowl Guard
- Dual Electronic Timer Control
- Reversible Bowl Drive
- Bowl Jog Control
- Front and Rear Casters
- Adjustable Front Stabilizing Feet
- Two Speeds
- Aluminum Cast Cover
- Steel Body Frame
- Powder Coat Finish

MODEL

- HSL180 – 180 lb. Spiral Mixer

Specifications, Details and Dimensions on Inside and Back.

**HSL180 SPIRAL MIXER**

HSL180 SPIRAL MIXER



701 S Ridge Avenue, Troy, OH 45374
1-888-4HOBART • www.hobartcorp.com

SOLUTIONS / BENEFITS

High Torque Motors

Durability

- Heavy-duty to meet the most demanding operations.
- Heavy-duty to meet the most demanding operations.

Stainless Steel Bowl

Rugged, Long Lasting

- Bowls are designed for long-term usage under heavy-duty conditions.

Stainless Steel Wireform Bowl Guard

Protection, Ease of Use

- Interlock prevents operation when front portion of guard is out of position.
- For observing and easy adding of ingredients without stopping mixer.

Dual 20 Minute Electronic Timer Controls

Convenience, Ease of Use, Recipe Consistency

- Lets you set the mixer for automatic shift from first to second speed.

Reversible Bowl Drive

Flexibility, Versatility

- Great for incorporating ingredients and mixing small batches.
- Gives you versatility and high production from a single unit.

Bowl Drive

Stability, Reliability, Long Lasting

- Rides on ball bearings, eliminates extra bowl support and adds durability.

Bowl Jog Control

Convenience, Ease of Use, Productivity

- Makes it easy to unload, gives you quicker batch turnaround.

HSL180 MIXER CAPACITY CHART

PRODUCT	Flour	Batch
Bread 60% AR	100 lb.	180 lb.*
Whole Wheat	100 lb.	190 lb.*
Thin Pizza 40% AR	62 lb.	90 lb.*
Med. Pizza 50% AR	80 lb.	125 lb.*
Light Pizza 60% AR	100 lb.	140 lb.*
Pie Dough	–	60 lb.□
Bagel 50% AR	90 lb.	140 lb.*

NOTE: % AR (% Absorption Ratio) - Water weight divided by flour weight. Capacity depends on moisture content of dough. Above capacities are based on 12% flour moisture content and 70°F water. Bread flour was used for bread dough capacities and high gluten flour was used for pizza and bagel doughs.

* If water temperature is under 55°F or if 25% or more of the water is ice, reduce batch size by reducing flour by 25 lbs. and other ingredients accordingly. Cold water or ice causes dough to be stiff and hard to mix, increasing the load on the mixer transmission and motor.

□ Pie dough can be successfully mixed in speed 1 with counterclockwise bowl rotation.

1 gallon of water weighs 8.33 lbs.



701 S Ridge Avenue, Troy, OH 45374
1-888-4HOBART • www.hobartcorp.com

HSL180 SPIRAL MIXER

SPECIFICATIONS

MOTORS:

High torque, ball bearing, totally enclosed, fan cooled, polyphase squirrel cage, induction run type. The spiral arm is two speed 3.5/6.4 H.P. The bowl motor is 1.0 H.P.

ELECTRICAL:

208/60/3, 26.1 amps. ETL Listed for Safety and Sanitation. Call for additional voltages.

CONTROLS:

Operator and main control boxes are dustproof. Magnetic contactors with automatic resetting thermal overload protection for each motor. "Start-Stop" push buttons. Reduced voltage fused pilot circuit. Direction of bowl rotation selectable by rotary switch. Bowl can be operated without spiral arm using "Bowl Jog" push button. Unit can operate in continuous mode or with timer.

BOWL GUARD:

Wireform, stainless steel. A bowl guard interlock is provided to prevent spiral arm operation when the guard is up.

TIMERS:

Dual electronic timer controls can be set between 0-20 minutes. Time for low and high speeds can be preset to increase productivity. Mixer will automatically shift from low to high speed when the time cycle is completed for low speed. Audible tone informs operator when mix cycle is completed. Large knob dial simplifies setting time.

DRIVES:

The spiral mix arm and the bowl have separate drive systems. Each uses a constant mesh helical gear train that is driven by its motor and multiple belt drive. All gears are lubricated. All shafts run on ball bearings.

SPEEDS:

Spiral arm speed "one" is 100 RPM. Speed "two" is 200 RPM. The bowl speed is 15 RPM.

BOWL:

Polished stainless steel, 150-quart capacity with center post.

CASTERS:

Ball bearing mounted front and rear casters allow easy movement for cleaning. Adjustable front stabilizing feet are provided.

FINISH:

Mixer is finished in gray powder coat paint. Top is gray liquid bicomponent paint.

WEIGHT:

(Approximate) Net: 1,246 lbs. Shipping: 1,446 lbs.

HSL180 SPIRAL MIXER



701 S Ridge Avenue, Troy, OH 45374
1-888-4HOBART • www.hobartcorp.com

DETAILS AND DIMENSIONS

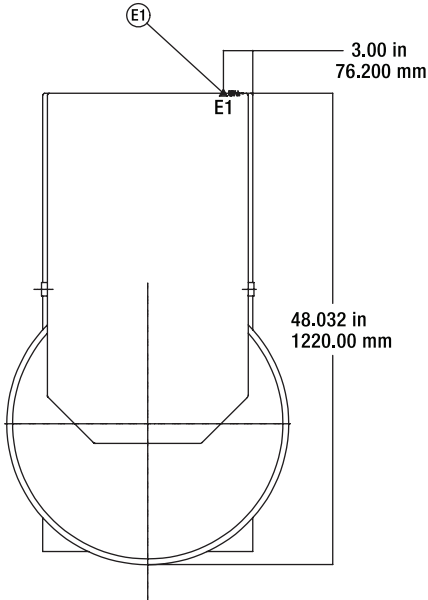

WARNING

ELECTRICAL AND GROUNDING CONNECTIONS
MUST COMPLY WITH THE APPLICABLE
PORTIONS OF THE NATIONAL ELECTRICAL
CODE AND/OR OTHER LOCAL ELECTRICAL CODES.

STANDARD MODEL:

NET WT (BOWL INCLUDED) 1246 LBS (565.2 KG)

DOMESTIC SHIPPING WT (BOWL INCLUDED) 1446 LBS (655.9 KG)

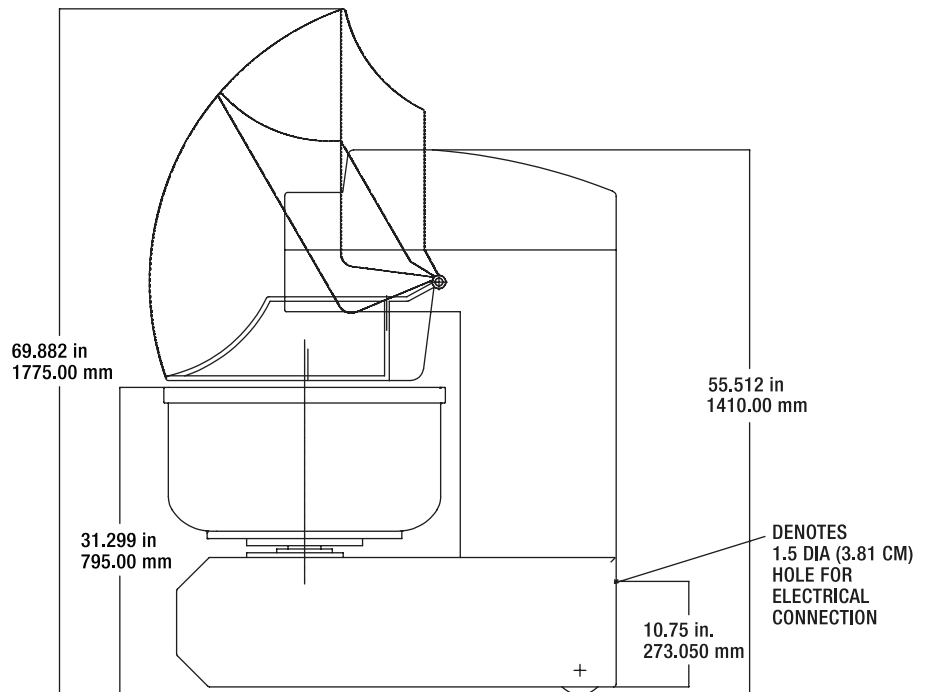
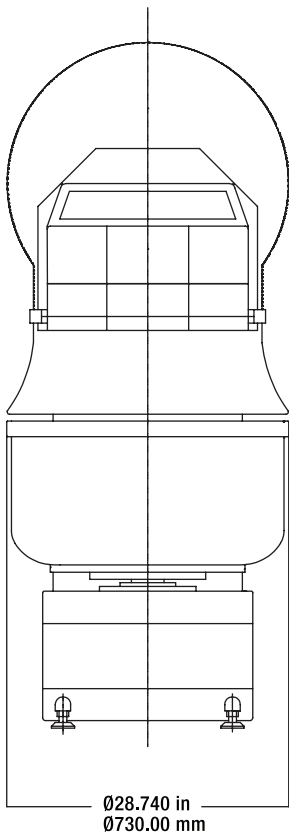

As continued product improvement is a policy of Hobart, specifications are subject to change without notice.