

**HOBART**701 S Ridge Avenue, Troy, OH 45374  
1-888-4HOBART • www.hobartcorp.com**HE SERIES  
ELECTRIC RANGES****HOBART****STANDARD FEATURES**

- Stainless steel front, sides, 23" flue riser with high shelf and 6" legs.
- Six 9½" round, solid cast iron, 2 KW French plates with infinite heat control switches.
- Full width pull out crumb tray.
- 5 KW oven with top browning control. Thermostat adjusts from 150° to 500°F.
- Cool to the touch control knobs.
- One oven rack with two rack positions.
- Requires 208V or 240V, 1 or 3 phase power supply.

**OPTIONS**

- 11" stainless steel back riser in place of standard back riser and shelf.
- Extra oven rack.
- Set of four casters (two locking).
- 12" x 24" hot top sections, 5 KW input, in place of one French top section. Thermostatically controlled and four position heat control.  
**NOTE:** Hot top sections increase power consumption and line amp draw. Consult customer service for KW and line amp information when specifying or ordering units with hot tops.
- Choice of 12", 24" or 36" wide, ½" thick griddle plate in place of French plate sections. One thermostat provided for each 12" griddle width. Griddles are supplied on the right side only and add 3" to the overall width of the range.

**MODELS**

- HE36L** – 36" Electric Range with three sets of French plates
- HE36SL** – with two sets of French plates and 12" griddle (right)
- HE36FL** – 36" Electric Range with one set of French plates and 24" griddle (right)

Specifications, Details and Dimensions on Reverse Side.

**HE SERIES ELECTRIC RANGES**

# HE SERIES ELECTRIC RANGES



701 S Ridge Avenue, Troy, OH 45374  
1-888-4HOBART • www.hobartcorp.com

## DETAILS AND DIMENSIONS

**OVEN INTERIOR DIMENSIONS:** 26¼" wide x 22½" d x 14½" h.  
One oven rack and two rack positions.

**OVEN EXTERIOR DIMENSIONS:** 36" w x 29¾" d x 59½" h on  
6" legs.

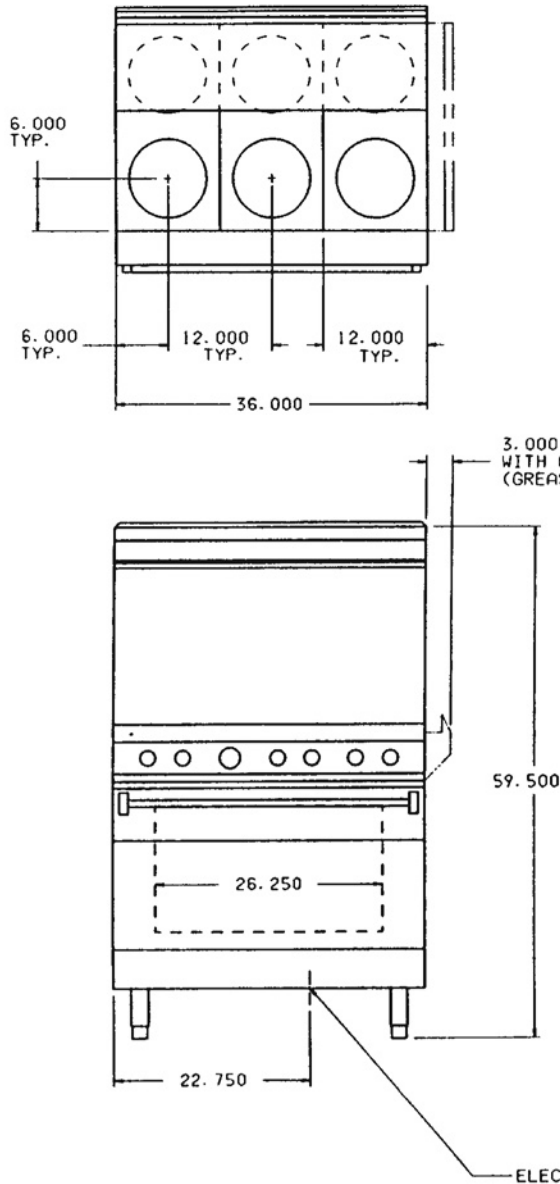

### CLEARANCES FROM COMBUSTIBLE CONSTRUCTION:

Range only..... 0" sides, 0" rear

Range and ESB salamander broiler..... 8" sides, 2" rear

**Clearance Note:** Electric Medium Duty Ranges 0 inches sides and rear from combustible and non-combustible constructions **except when hot top sections are incorporated.** Ranges incorporating hot top sections are 0" sides and rear to non-combustibles and 6" sides and rear to combustibles constructions.

### SPECIFY VOLTAGE AND PHASE WHEN ORDERING.

This appliance is manufactured for commercial installation only and not intended for domestic/household installation.

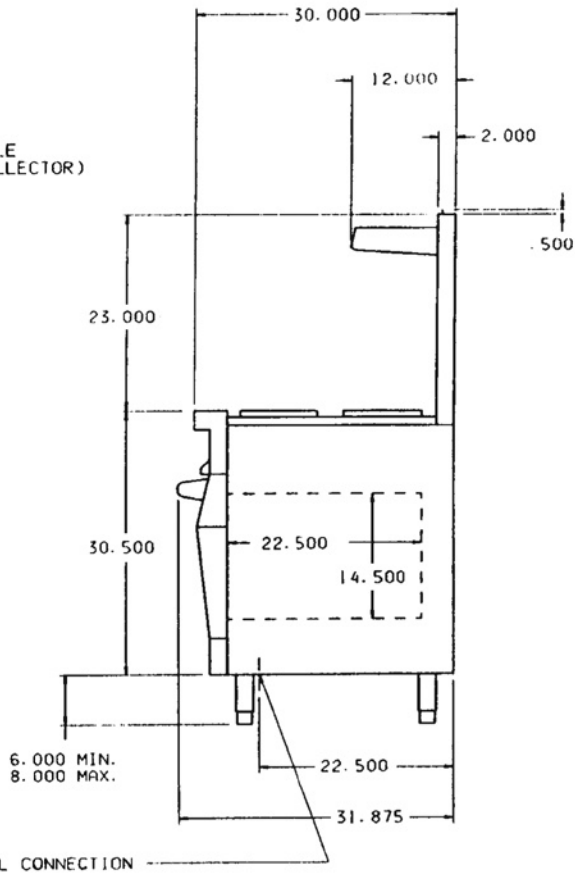

### AVAILABLE VOLTAGES - 208 OR 240 VOLT - 1 OR 3 PHASE

MODEL NO.	TOTAL CONN. KW	3 PHASE LOADING		NOMINAL AMPS PER LINE WIRE											
		KW PER PHASE			3 PHASE									1 PHASE	
		X-Y	Y-Z	X-Z	208V			240V			480V			208V	240V
				X	Y	Z	X	Y	Z	X	Y	Z			
HE36L	17.0	4.0	8.0	5.0	37.5	50.0	54.1	32.5	43.3	46.9	16.3	21.7	23.5	81.7	70.8
HE36SL	16.4	4.0	7.4	5.0	37.5	47.5	51.6	32.5	41.1	44.7	16.3	20.6	22.4	78.8	68.3
HE36FL	15.8	4.0	6.8	5.0	37.5	45.0	49.1	32.5	39.0	42.6	16.3	19.5	21.3	76.0	65.8

As continued product improvement is a policy of Hobart, specifications are subject to change without notice.