

HOBART701 S Ridge Avenue, Troy, OH 45374
1-888-4HOBART • www.hobartcorp.com**KA SERIES SELF-CLEANING
ELECTRIC ROTARY OVEN****HOBART****KA SERIES SELF-CLEANING ELECTRIC ROTARY OVEN****STANDARD FEATURES**

- Automatic, Self-Cleaning Oven
- Marquee Display
- Easy-to-Use Programmable Controls on Load Side
 - Automatic Clean Button
 - 4 Stage Cooking
 - 99 Cook Program Capacity
 - Add 5 Minute Cook Time
 - NAFEM Protocol Ready Controls
- Pass-Thru Control Located on the Unload Side
 - Snooze - to Add 10 Minute Cook Time
 - Silence Buzzer - to Enter Hold Mode
 - Stop - Ends Cook Cycle
- "Hands-Free" Rotate Button for Ease of Loading and Unloading on Both Sides
- Large Viewable Tempered Glass Doors
- Hinged Inner Door for Ease of Cleaning
- 500 W Cavity Light for High Visual Impact
- Automatic Chemical Injection for Cleaning
- Automatic Grease Removal
- Removable Rotor and Drip Strainers
- Convection and Radiant Heat Plus Self-Basting Action
- Stainless Steel Interior
- Stainless Steel Exterior
- Individual Power Connections
- Modular Construction (Stackable)

MODEL

- KA7E** – Self-Cleaning; 28-35 Chicken Capacity

ACCESSORIES**(Must be ordered separately – all models shipped without spits)**

- 7 Spits
- 7 V-Spits
- 7 Baskets
- 7 ThermoWave Spits
- 7 Four Position Chicken Racks
- 7 Five Position Chicken Racks
- Stand with Door and Pull-Out Shelf
- 4" Legs and Mounting Brackets
- Stacking Kit with Casters
- Spit Rack 7 x 2
- Grease Disposal Vessel
 - Plastic Container

Specifications, Details and Dimensions on Inside and Back.



KA SERIES SELF-CLEANING ELECTRIC ROTARY OVEN



701 S Ridge Avenue, Troy, OH 45374
1-888-4HOBART • www.hobartcorp.com

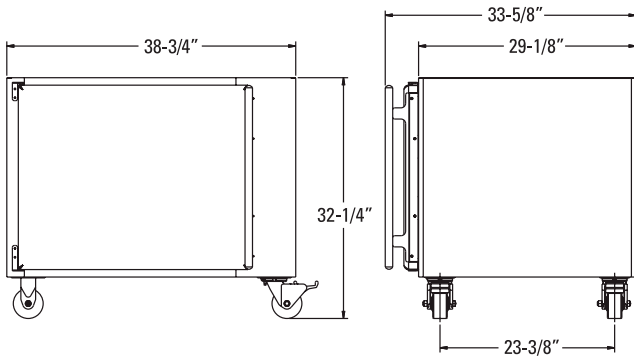
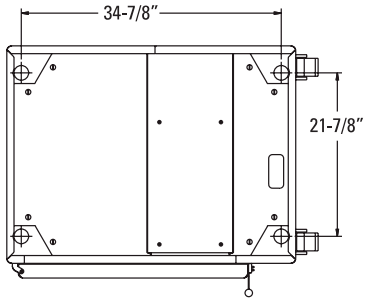

STAND-KA7E

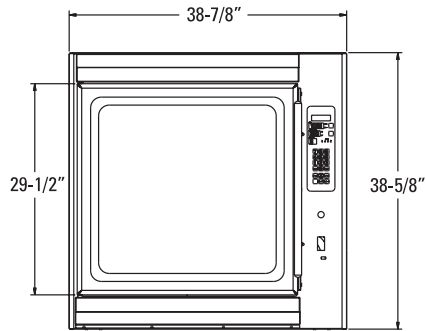

FRONT VIEW
KA7E ROTISSERIE

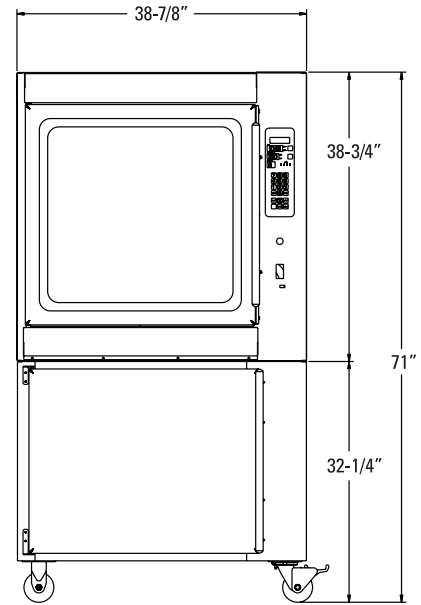

KA7E ROTISSERIE WITH
STAND ACCESSORY

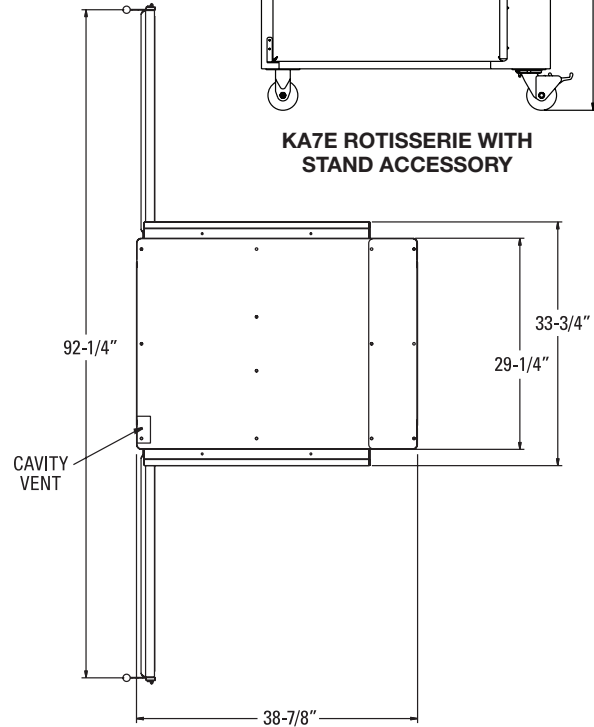

TOP VIEW
KA7E ROTISSERIE

DIMENSIONS, WITHOUT LEGS OR CASTERS AND WEIGHTS:

MODEL	DEPTH	WIDTH	HEIGHT	NET WT.	SHIPPING WT.
STAND-KA7E	33 $\frac{1}{2}$ "	38 $\frac{3}{4}$ "	32 $\frac{1}{4}$ " w/casters	—	153 lbs.
KA7E	33 $\frac{5}{8}$ "	38 $\frac{7}{8}$ "	38 $\frac{5}{8}$ " w/o legs or casters	480 lbs.	525 lbs.

STACKED MODELS DIMENSIONS WITH CASTERS:

MODEL	DEPTH	WIDTH	HEIGHT	TYPE
KA7E + STAND-KA7E	33 $\frac{5}{8}$ "	38 $\frac{7}{8}$ "	71"	ROTISSERIE ON STAND
KA7E + KA7E	33 $\frac{5}{8}$ "	38 $\frac{7}{8}$ "	81 $\frac{5}{8}$ "	STANDARD STACKING KIT

CASTER CONFIGURATION

Standard Stacking Kit: 2 locking swivel casters, 2 locking rigid casters



701 S Ridge Avenue, Troy, OH 45374
1-888-4HOBART • www.hobartcorp.com

KA SERIES SELF-CLEANING ELECTRIC ROTARY OVEN

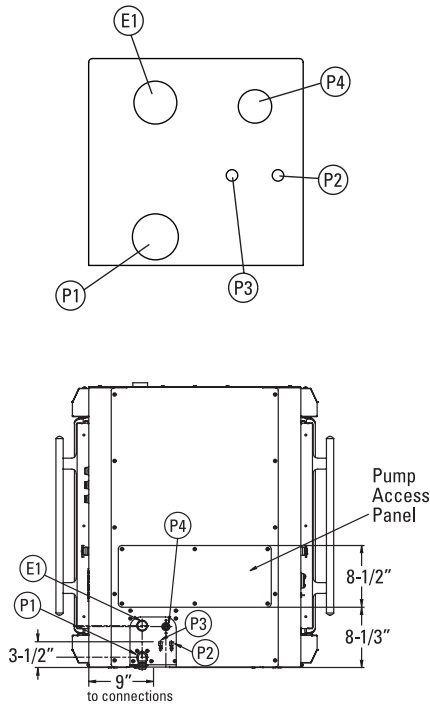

**RIGHT SIDE VIEW
KA7E ROTISSERIE**

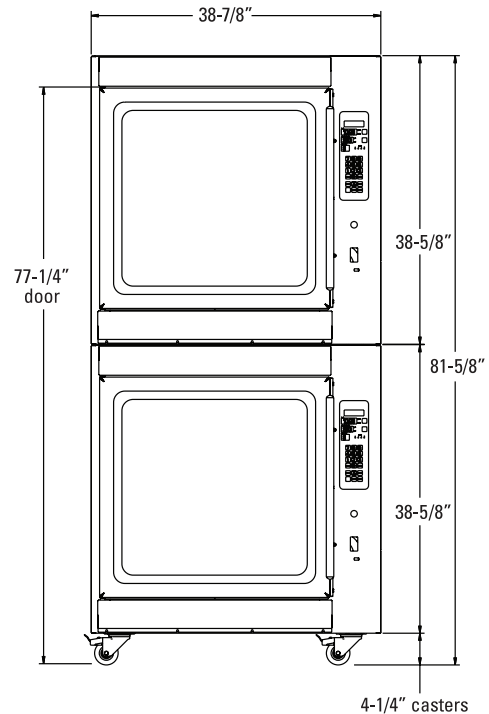

**KA7E ROTISSERIE with
KA7E ROTISSERIE
USING STACKING KIT ACCESSORY**

CONNECTION INFORMATION: Allow 3" minimum right side clearance for plumbing connections for stacked and counter-top configurations. (Note: Clearances up to 12" may be necessary when optional grease disposal vessel or chemicals are stored on the right side of rotisserie oven.) 0" clearance to back and sides for optional* out-of-sight drop-through utility connections into stand accessory.

*Drop-through utilities relocation kit is included with stand accessory. Refer to local codes for hood requirements.

LEGEND

- (P1) Water Drain:** 1" female NPT piped to open drain. No solid connections. Output 140°F max. at 5 GPM.
- (P2) Chemical Supply:** Hose barb to accept 1/4" ID chemically resistant tubing, supplied with machine. Use only Kay Chemical CIP cleaner, or approved cleaner, to ensure proper operation.
- (P3) Grease Drain:** Hose barb to accept 1/4" ID high temperature tubing, supplied with machine, 212°F rated.
- (P4) HOT Water Supply:** 3/4" male hose bib fitting. 0.5 GPM @ 25-50 psi. 120°F-140°F. Recommended hardness, 4-6 grains. Minimum conductivity required, 30 MICROMHOS/CM.

(E1) ELECTRICAL:

60 HZ		KA7E	
VOLTAGE	PHASE	WATTAGE	AMPERAGE
208	1	9,300	42.8
240	1	9,300	37.7
208	3	9,300	24.7
240	3	9,300	21.8

Field wire electrical connection 1 1/4" and/or 1 1/2" K.O.
Stacked units must be wired independently.

KA SERIES SELF-CLEANING ELECTRIC ROTARY OVEN



701 S Ridge Avenue, Troy, OH 45374
1-888-4HOBART • www.hobartcorp.com

SPECIFICATIONS:

CAPACITY: KA7E: 28-35 chickens.

Automatic self-cleaning feature. Automatic grease removal. Automatic chemical injection. Automatic water fill and drain. Rugged wash pump runs spray arm and nozzles in cavity.

Stacked units are mounted on nylon casters. Countertop units mounted on adjustable legs – 4" to 6".

Top-mounted fans draw air from bottom of oven cavity over the top mounted heating elements browning product evenly on all sides.

Cavity illuminated with 500W long-life lamp.

Spit motor rotates at 2 RPM.

Stacked units must be wired independently.

CONSTRUCTION: Outer shell is stainless steel. 1" Rock-wool insulation is applied to top and sides. Doors mounted on both front and back feature large, full sized tempered glass for high visual impact. Each door swings open 180°. Spits are easy to remove without the use of tools for product removal and to facilitate cleaning. Oven interior is stainless steel. Perforated drip strainers prevent skin and bones from dropping into wash sump. Perforations allow for automatic grease disposal.

CONTROLS: Standard pass-through configuration has 500 W lamp and operator controls located on the right side panel on the load side of the oven. The select control capability (*snooze, silence buzzer, stop and rotate*) is located on the left side panel on the unload side of the oven for pass-through operation.

IMPORTANT: Grease disposal container and chemical container should be placed no farther than 6 feet away from oven.

Use only Kay Chemical CIP, or other approved cleaner to insure proper operation of machine.

Steam generated from normal operation may escape from the door. Wood laminate, veneers, etc. are unsuitable materials for use in areas exposed to self-cleaning oven steam and detergents. Stainless steel or other moisture-resistant shields are recommended for surfaces adjacent to KA7E sides and top.

WEIGHT:	Net. Wt.	Approx. Ship Wt.
Stand-KA7E	–	153
KA7E - Glass Back	480	525

(accessories shipped separately)



KA7E
shown with pass-thru option



KA7E
shown with stand accessory



KA7E/KA7E
shown with stacking kit accessory

As continued product improvement is a policy of Hobart, specifications are subject to change without notice.