



701 S Ridge Avenue, Troy, OH 45374
1-888-4HOBART • www.hobartcorp.com

HBP SERIES HOLDING/TRANSPORT CABINETS

HOBART

STANDARD FEATURES

- Heavy duty polished stainless steel cabinet with tubular steel inner frame for increased durability.
- Four 5" casters, two locking swivel.
- Extended bumper assembly.
- Stainless steel door with heavy duty hinges and door latch mechanisms, and long lasting silicone gaskets.
- Cabinet and door filled with 1" thick fibrous insulation, 2" insulation in top.
- Interior pan supports are removable for easy cleaning.
- Interior humidifier in bottom of cabinet for foods requiring extra moisture.
- Recessed control panel includes power "on" and heater "on" indicator lights, dial thermostat adjustable from 60° to 200°F, and temperature read-out dial.
- Two 600 watt metal sheathed heating elements, 1,200 watts total input. 10 amps total draw. Requires 120 volt, 60 Hz, 1 phase power supply. Furnished with 6' power cord and NEMA 5-15 plug.

OPTIONS

- Pass-thru door.
- Stacking kit (HBP7 only).
- 208 or 240 volt, 1 phase, 6' cord with NEMA 6-15 plug.
- Extra pair of universal slides.
- 18" x 26" wire basket.
- 18" x 13" wire basket.
- Set of four legs, adjustable from 4" to 5½".
- Set of four 5" locking swivel casters.
- Top mounted bumper.
- Stainless steel dutch doors (HBP13/15).
- Dutch doors, glass (HBP15l only).

MODELS

- HBP7I** Seven level holding and transport cabinet accepts seven 18" x 26" x 1" baking pans or fourteen 12" x 20" x 2½" hotel steam pans.
- HBP13I** Thirteen level holding and transport cabinet accepts thirteen 18" x 26" x 1" baking pans or twenty-six 12" x 20" x 2½" hotel steam pans.
- HBP15I** Fifteen level holding and transport cabinet accepts thirty 18" x 26" x 1" baking pans or twenty-six 12" x 20" x 2½" hotel steam pans.

Details and Dimensions on Reverse Side.



HBP SERIES HOLDING/TRANSPORT CABINETS

HBP SERIES HOLDING/TRANSPORT CABINETS



701 S Ridge Avenue, Troy, OH 45374
1-888-4HOBART • www.hobartcorp.com

CONSTRUCTION:

Heavy duty polished stainless steel cabinet with tubular steel inner frame for increased durability. Stainless steel door with heavy duty hinges and door latch mechanism, and long lasting silicone gaskets. Cabinet and door filled with 1" thick fibrous insulation, 2" insulation in top.

Interior pan supports are removable for easy cleaning. Accepts 18" x 26" x 1" baking pans or 12" x 20" x 2½" hotel steam pans. Interior humidifier in bottom of cabinet for foods requiring extra moisture.

CONTROLS:

Recessed control panel includes power "on" and heater "on" indicator lights, dial thermostat adjustable from 60° to 200°F, and temperature read-out dial.

ELECTRICAL:

Two 600 watt metal sheathed heating elements per section, 1,200 watts total input. 10 amps total draw. Requires 120 volt, 60 Hz, 1 phase power supply. Furnished with 6' power cord and NEMA 5-15 plug.

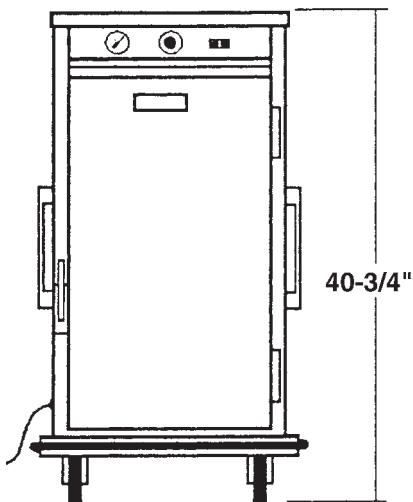
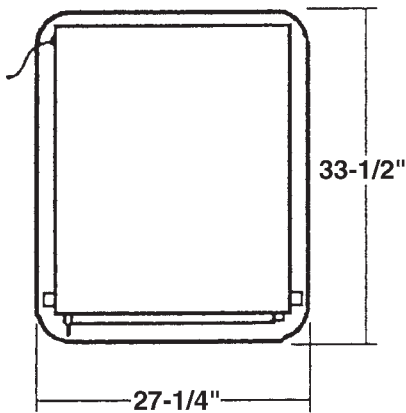

HBP7I

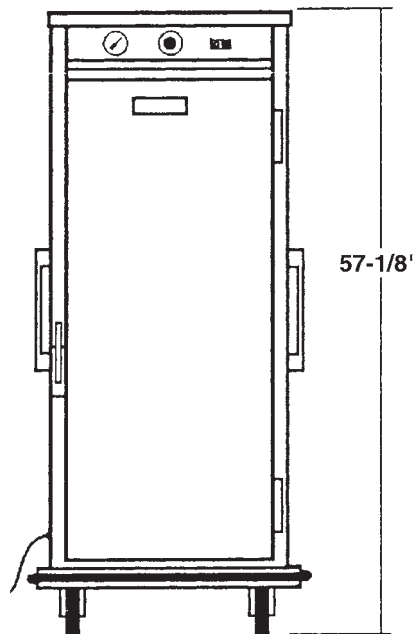

HBP13I

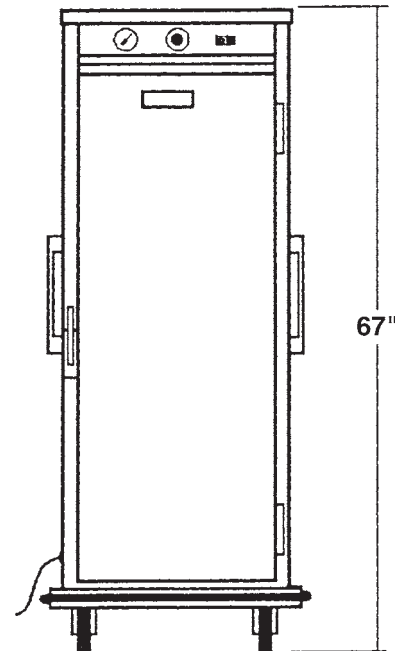

HBP15I

Model No.	Capacity per Compartment	Body Dimensions						Electrical Specifications			Ship. Wt. (approx.)
		W/Bumper & Caster Assy.			W/O Bumper & Caster Assy.			Volts	Watts	Amps	
		Height	Depth	Width	Height	Depth	Width				
HBP7I	7 - 18" x 26" x 1" 14 - 12" x 20" x 2½"	40¾"	33½"	27¼"	40¾"	30½"	24¼"	120	1200	10	206 lbs.
HBP13I	13 - 18" x 26" x 1" 26 - 12" x 20" x 2½"	57⅞"	33½"	27¼"	57⅞"	30½"	24¼"	120	1200	10	290 lbs.
HBP15I	15 - 18" x 26" x 1" 30 - 12" x 20" x 2½"	67"	33½"	27¼"	67"	30½"	24¼"	120	1200	10	345 lbs.

As continued product improvement is a policy of Hobart, specifications are subject to change without notice.