

HOBART701 S Ridge Avenue, Troy, OH 45374
1-888-4HOBART • www.hobartcorp.com**HBP7I HOLDING &
TRANSPORT CABINET****HOBART****STANDARD FEATURES**

- Heated holding and transport cabinet with a capacity of 7 each 18" x 26" sheet pans, 14 each 12" x 20" x 2½" pan, or a combination of both on 3" centers
- Heavy duty 5" casters (2 swivel with brake, 2 rigid)
- Recessed control panel containing dual indicator light (red when connected to power and amber when heating elements are in operation), thermometer, and full range thermostat for temperatures up to 190°F
- Fully insulated 1½" side walls and 2" in top
- Heavy duty polished 300 series stainless steel construction; 20 gauge exterior, 22 gauge interior
- Removable universal tray slides provide for easy cleaning
- 4 pairs of universal tray slides adjustable on 1½" centers for each cabinet
- 120 volt, 1200 watts, 10 amp
- Complete with 6' heavy duty cord and NEMA 5-30 plug
- Positive action door latch

OPTIONS

- Complete with full perimeter bumper
- 208/240 volt (no charge)
- 1000 watt elements (no charge)
- Stainless steel legs
- 4" and 6" heavy duty casters
- Security package
- Left hand hinge door (no charge)
- Stacking kit
- Top mounted bumper
- 18" x 26" wire basket
- 18" x 13" wire basket

MODEL

- HBP7I — Holding and Transport Cabinet

OPTIONS (Continued)

- Card holder
- Cord wrap
- Electronic temperature control
- Additional universal tray slides
- Humidity pan

Specifications, Details and Dimensions on Reverse Side.

**HBP7I HOLDING & TRANSPORT CABINET**

HBP7I HOLDING & TRANSPORT CABINET



701 S Ridge Avenue, Troy, OH 45374
1-888-4HOBART • www.hobartcorp.com

DETAILS AND DIMENSIONS

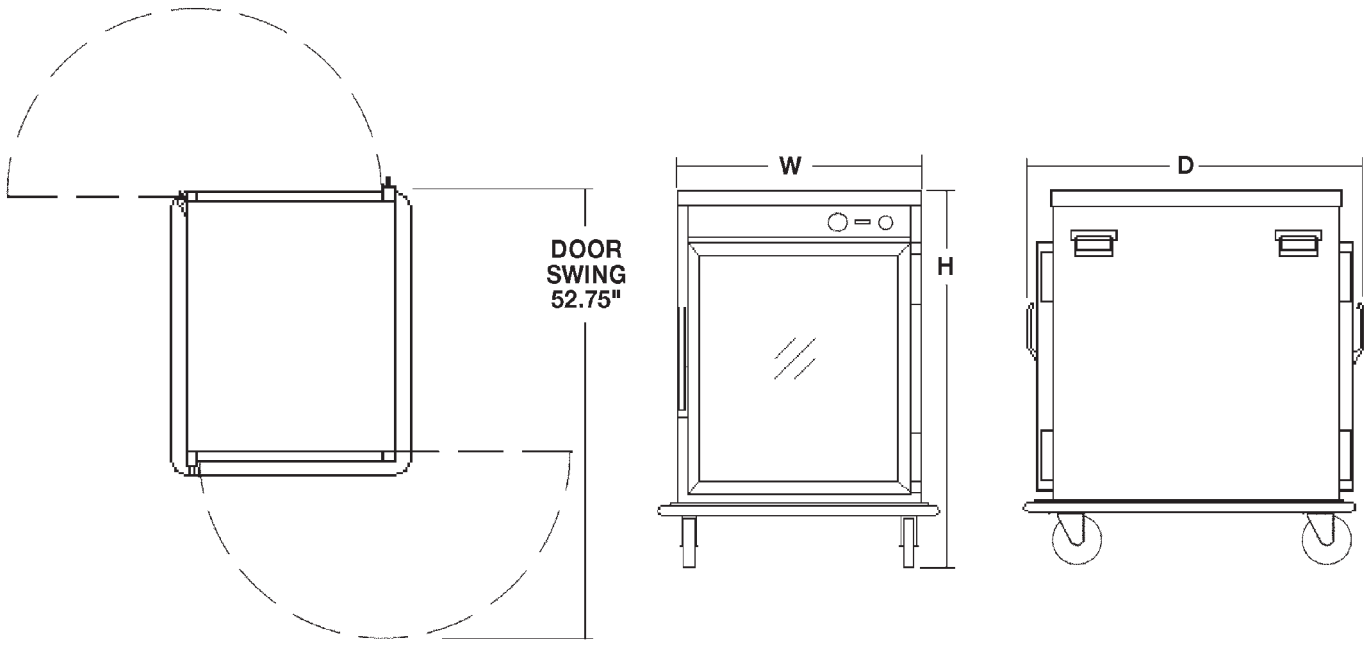

Pass-through

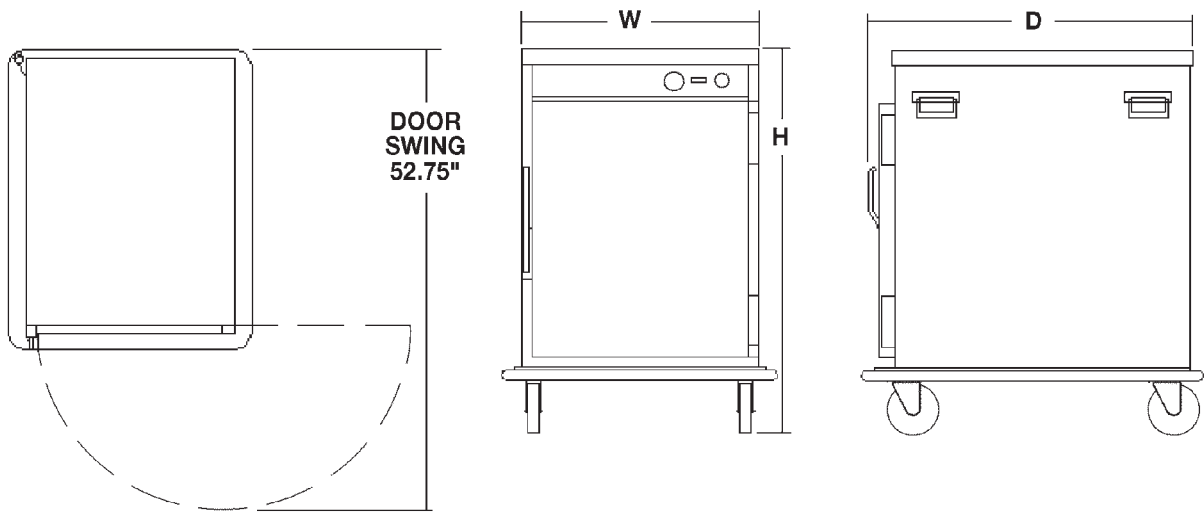

Standard

Model No.	Capacity 12" x 20" x 2 1/2"	Capacity 18" x 26"	High	Deep	Wide	Shipping Weight	Volts	Watts	Amps
HBP7I	14	7	37 3/4"	33 3/4"	28 1/4"	230 lbs.	120	1200	10

As continued product improvement is a policy of Hobart, specifications are subject to change without notice.