

HOBART

FOOD EQUIPMENT

CG SERIES ELECTRIC COUNTER GRIDDLES

CG20 - 2 ft. Model -
24" W x 25⁵/₃₂" D

CG55 - 3 ft. Model -
36" W x 21¹¹/₁₆" D

CG58 - 3 ft. Model -
36" W x 27⁵/₈" D

CG41 - 4 ft. Model -
38" W x 27⁵/₈" D

CG59 - 6 ft. Model -
72" W x 27⁵/₈" D

HIGH PRODUCTION, UNIFORM PERIMETER HEATING

- **Griddle surface is thermostatically controlled in 12" zones** — Allows food to be cooked at optimal temperature; allows various products to be cooked simultaneously at different temperatures.
- **Thermostat bulb located in center of each 12" zone** — Allows fast, accurate response to different load conditions within each 12" zone.
- **Stainless steel heating elements with uniform heat pattern** — Eliminates hot and cold spots; reduces maintenance.
- **Heating elements pressure clamped to griddle surface** — Provides maximum heat transfer to griddle surface.
- **Heating element cycle light** — Indicates if elements are heating or when griddle has reached preset temperature.
- **3" backsplash welded to bottom of griddle plate** — Prevents grease splash out; reduces clean-up time and improves sanitation.

- **Full width grease trough** — Allows scraping at any point on griddle surface; eases cleaning.
- **Full depth grease drawer with anti-splash baffle** — Increases grease storage capacity.
- **Enclosed grease drawer compartment** — Prevents evaporation of grease into internal components of griddle.
- **1/2" Thick polished steel griddle plate** — For fast response and accurate temperature control; easily cleaned. Top swings up for easy accessibility for service.
- **Stainless steel griddle body** — Extends equipment life; improves sanitation.

Specifications, Details and Dimensions Inside.

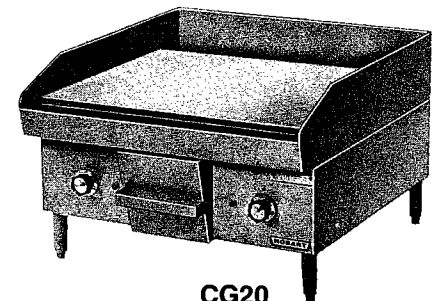

CG20



CG55-58

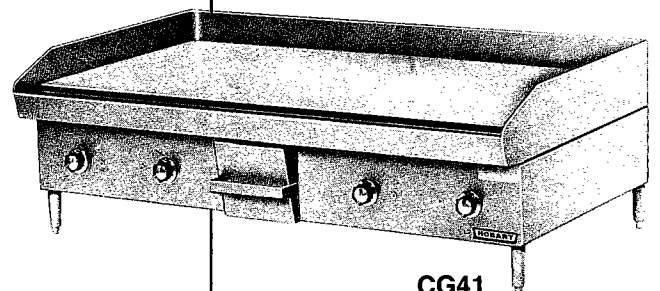

CG41

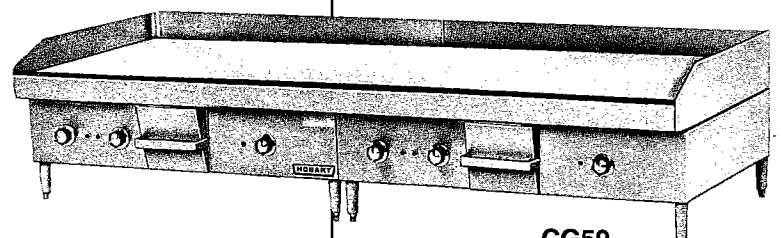

CG59

CG SERIES ELECTRIC COUNTER GRIDDLES

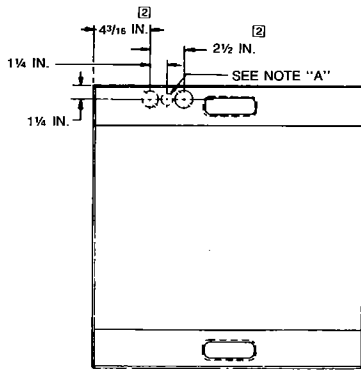

TOP VIEW

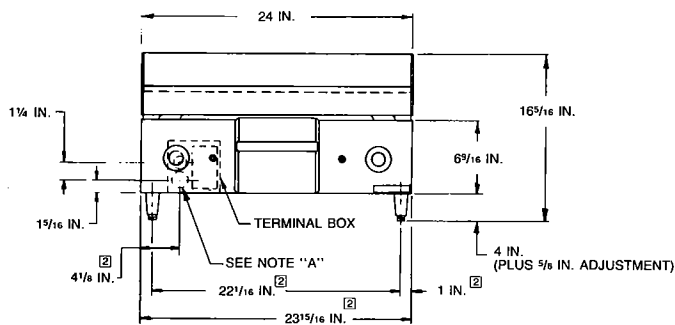

FRONT VIEW

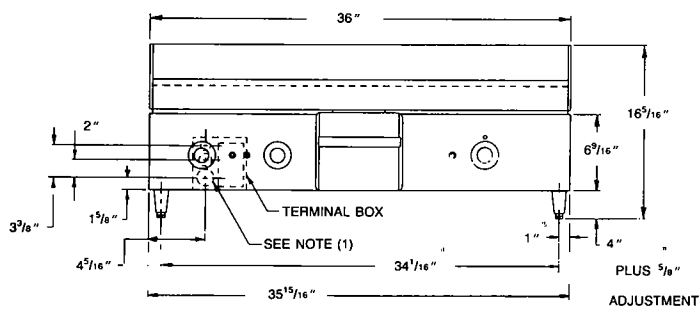

FRONT VIEW

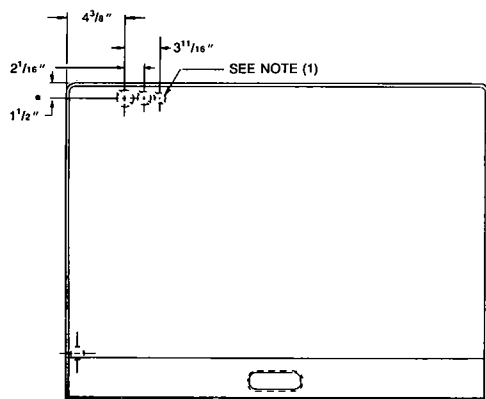

TOP VIEW

INSTALLATION RESTRICTIONS:
WHEN INSTALLING GRIDDLE, SIDE(S) MUST BE 1" FROM WALL(S)
AND BACK MAY BE FLUSH WITH WALL.

NOTE "A"
1 1/8 IN., 1 9/16 IN. & 1 7/16 IN. DIA. KNOCKOUT IN BACK
AND BOTTOM FOR CONDUIT ENTRANCE.

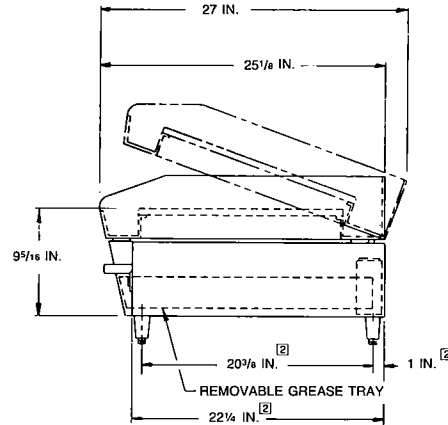

SIDE VIEW

CG20

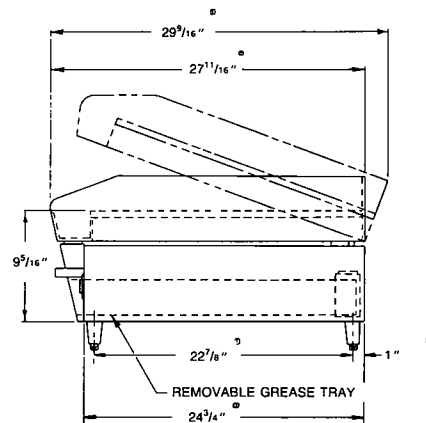

SIDE VIEW of CG58

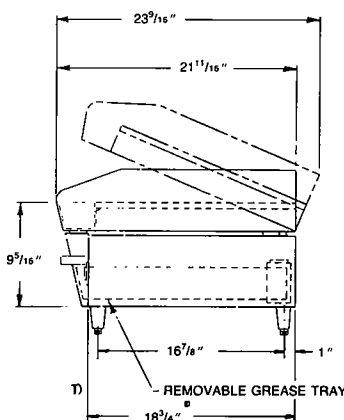

SIDE VIEW of CG55

NOTE (1):
1 1/8", 1 7/16" & 1 3/4" DIA. KNOCKOUTS IN BACK
AND BOTTOM FOR CONDUIT ENTRANCE.

(2) GRIDDLE SIDE(S) MUST BE 1" FROM WALL(S) AND
THE BACK MUST BE 1" FROM THE WALL.



CG55-58

CG SERIES ELECTRIC COUNTER GRIDDLES

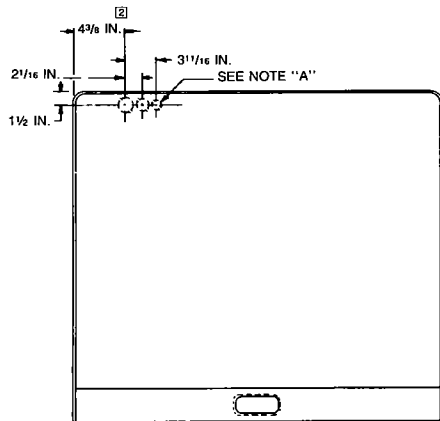

TOP VIEW

INSTALLATION RESTRICTIONS:
WHEN INSTALLING GRIDDLE SIDE(S) MUST BE 1" FROM WALL(S) AND BACK MUST BE 1" FROM WALL.

NOTE "A"
1 1/8 IN., 1 7/16 IN., 1 3/4 IN. DIA. KNOCKOUT IN BACK AND BOTTOM FOR CONDUIT ENTRANCE.

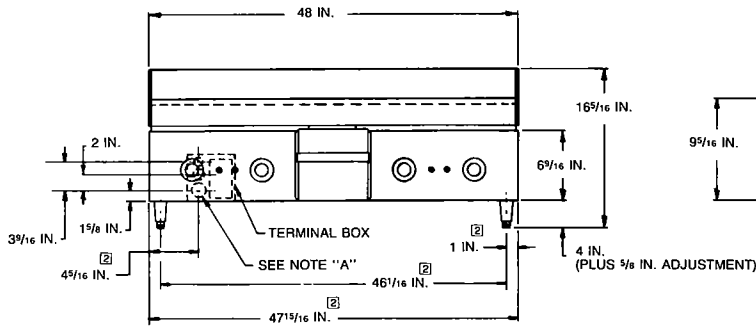

FRONT VIEW

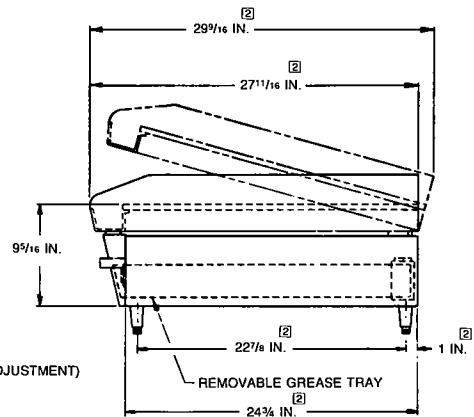

SIDE VIEW

CG41

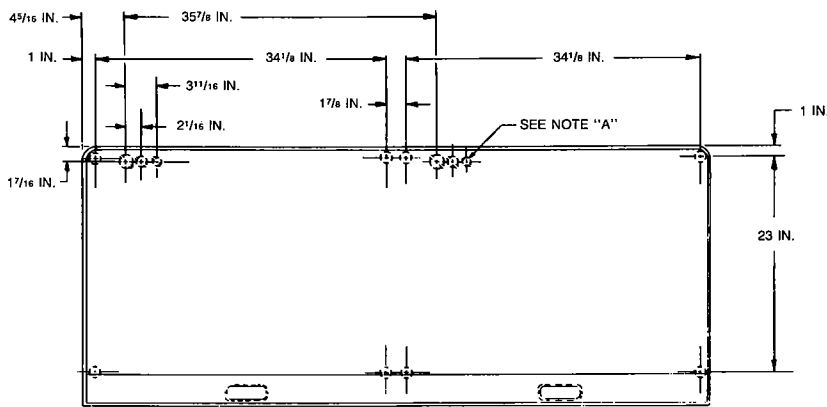

TOP VIEW

INSTALLATION RESTRICTIONS:
When installing the CG59 griddle, the side(s) must be 1" from the wall(s) and the back must be 1" from the wall.

NOTE "A"
1 1/8 IN., 1 7/16 IN. & 1 3/4 IN. DIA. KNOCKOUT IN BACK AND BOTTOM FOR CONDUIT ENTRANCE.

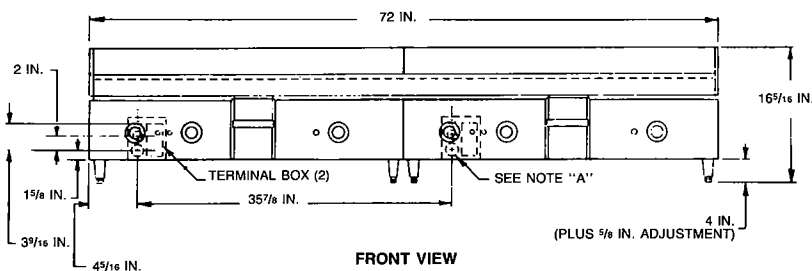

FRONT VIEW

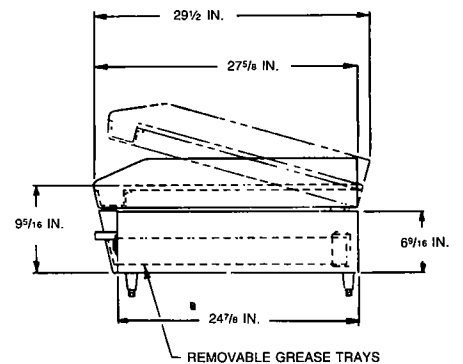

SIDE VIEW

CG59

CG SERIES ELECTRIC COUNTER GRIDDLES



SPECIFICATIONS Listed by Underwriters Laboratories Inc and by National Sanitation Foundation.

CONSTRUCTION: Stainless steel free-standing counter-style griddle. Stainless steel heating units with a 1/2" thick polished steel griddle plate. Cold-rolled steel 3" high splatter guard welded to griddle plate bottom. 4" high plastic legs with adjustable feet. A full-width front and rear grease trough directs grease to a removal chute. Full depth grease drawer with weep hole is front removable. (Model CG59 has two grease removal chutes and drawers.) Wrap-around grease guard protects wall and equipment from splatter.

HEATING: Uniform pattern of enclosed tubular stainless steel heating units

eliminates hot and cold spots. Perimeter is heated and units are attached to grid bottom. Extra heat-retaining baffle reduces watts to hold. Preheats to 350°F in just 7 minutes.

CONTROLS: A thermostat provides independent controls of each 12" wide area of grid. Temperature range is 200-450°F. A signal light for each thermostat indicates whether or not that it is operating and when preset temperature is reached.

ELECTRICAL: See "Electrical Data" block for Total KW, Watts to Hold and

phase loading. Left rear terminal box. (CG59 power terminal box are at left rear and center rear.) Knockouts in back and bottom permit connections to suit varied conditions.

ACCESSORIES: Stand without casters; Stand with casters; adjustable chrome plated legs.

As continued product improvement is a policy of Hobart, specifications are subject to change without notice.

ELECTRICAL DATA

TOTAL KW	WATTS TO HOLD 400F	PHASE-LOADING AND LINE AMPERES									
		3-PHASE LOADING			NOMINAL AMPERES PER LINE						
		KW PER PHASE			3-PHASE			1-PHASE			
		L1-L2	L2-L3	L1-L3	208 VAC	240 VAC	480 VAC	208 VAC	240 VAC	480 VAC	
CG20	8.0	1205	4.0	0.0	4.0	38.5	28.9	14.4	38.5	33.3	16.7
CG41	21.6	2100	10.8	5.4	5.4	68.7	59.5	29.8	103.9	90.0	45.0
CG55	12	1808	4.0	4.0	4.0	33.4	28.9	14.4	57.7	50.0	25.0
CG58	16.2	2100	5.4	5.4	5.4	45.0	39.0	19.5	77.9	67.5	33.8
CG59	32.4*	42.0	5.4	5.4	5.4	45.0	39.0	19.5	77.9	67.5	33.8

Rated voltages: 208, 240, 480 VAC; 1 or 3 phase, 50/60 Hz.

*NOTE: Two separate conduit connections must be made; each connection carries one-half of the rated load.

GENERAL & DIMENSIONAL DATA

MODEL	OVERALL BODY DIMENSIONS			GRID SURFACE DIMENSIONS			TYPICAL PRODUCTION								WEIGHTS	
	W	D	H (LESS LEGS)	W	D	SQUARE AREA	HAMBURGERS (2 1/2 OZ., 3 1/2" DIA.)		PANCAKES (4" DIA.)		MIN. STEAKS (4 OZ., 1" THICK)		FRIED EGGS		SHIP	NET
							QTY/LOAD	QTY/HOUR	QTY/LOAD	QTY/HOUR	QTY/LOAD	QTY/HOUR	QTY/LOAD	QTY/HOUR		
CG20	24	25 5/32	9 5/16	24	18	432	32	460+	21	260-320	12	145+	30	450+	165	140
CG41	48	27 5/8	9 5/16	48	24	1140	86	1300+	53	600+	32	400+	86	1200+	275	250
CG55	36	27 11/16	9 5/16	36	18	642	48	720+	32	380-480	18	216+	45	675+	190	168
CG58	36	27 5/8	9 5/16	36	24	855	65	975+	40	450+	24	300+	65	900+	230	207
CG59	72	27 5/8	9 5/16	72	24	1710	120	2400+	80	900+	48	700+	130	1800+	560	445



WORLD HEADQUARTERS
TROY, OHIO 45374