



701 S Ridge Avenue, Troy, OH 45374  
1-888-4HOBART • www.hobartcorp.com

## 1HG65M GAS FRYER



### STANDARD FEATURES

- Large cold zone area
- Twin fry baskets with plastic coated handles
- Behind the door snap action millivolt thermostat control adjusts from 200° to 400°F with standing pilot
- Both Fahrenheit and Celsius scales
- Millivolt system – requires no electric hook-up
- Built-in flue deflector
- Nickel plated tube rack
- Earth magnet to secure closed door
- Easily removable stainless steel basket hanger for cleaning
- Stainless steel fry tank, 65 - 70 lb. capacity
- 1¼" full port ball type drain valve
- Stainless steel cabinet
- Set of four casters (two locking)
- 150,000 BTU/hr. input
- Four heat exchanger tubes positioned for easy cleaning
- High limit shut-off protector shuts off gas combination valve and standing pilot
- Tank brush, stainless steel crumb scoop and clean-out rod
- One year limited parts and labor warranty
- Ten year limited fry tank warranty

### ACCESSORIES

- Frymate VX15 add on dump station
- Stainless steel tank cover doubles as a work surface top
- Connecting kit(s) – Connect two fryers together (banking strip, brackets and hardware included)
- Single large basket – 18½"w x 13¼"d x 6"h
- Extra set of twin baskets – 9¼"w x 13¼"d x 6"h
- 10" high stainless steel removable splash guard
- Flexible gas hose with quick disconnect and restraining device.

### MODELS

- 1HG65M:** Behind the door millivolt thermostat control adjusts from 200° to 400°F.

Specifications, Details and Dimensions on Reverse Side.



1HG65M

1HG65M GAS FRYER

# 1HG65M GAS FRYER



701 S Ridge Avenue, Troy, OH 45374  
1-888-4HOBART • www.hobartcorp.com

## SPECIFICATIONS

### CONSTRUCTION:

65 - 70 lb. capacity floor model gas fryer. Stainless steel front, top, sides and door. Stainless steel fry tank with five heat exchanger tubes and a "V" shaped cold zone. Set of four casters (two locking), 1" full port ball type drain valve. Twin fry baskets with plastic coated handles.

### TANK SIZE:

19½" x 14".

### HEATING:

150,000 BTU/hr. input.

### WORKING HEIGHT:

36¼".

### APPROXIMATE SHIPPING WEIGHT:

275 lbs.

## DETAILS AND DIMENSIONS

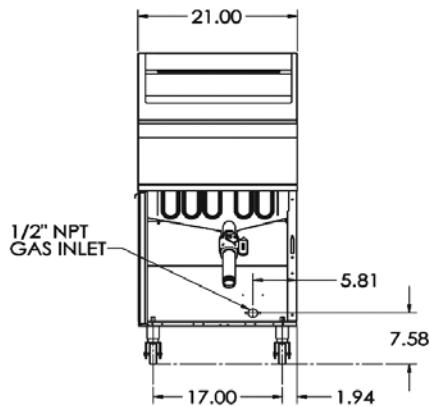

Front View

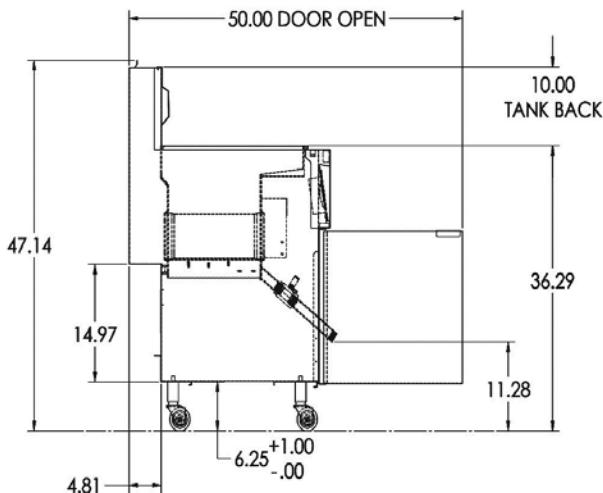

Side Views

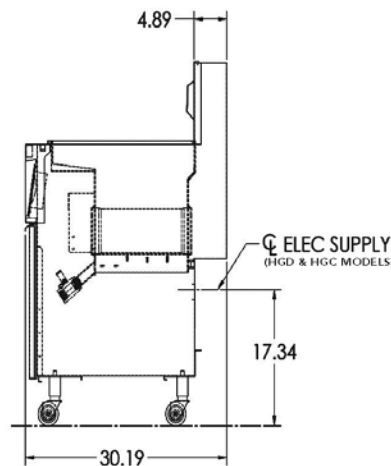

Top View

### IMPORTANT

1. A combination valve with pressure regulator is provided with this unit.  
Natural Gas 4.0" W.C.  
Propane Gas 10.0" W.C.
2. An adequate ventilation system is required for Commercial Cooking Equipment. Information may be obtained by writing to the National Fire Protection Association, Batterymarch Park, Quincy, MA 02269. When writing refer to NFPA No. 96.
3. All models require a 6" clearance at both sides and rear adjacent to combustible construction.
4. All models require a 16" minimum clearance to adjacent open top burner units.
5. This appliance is manufactured for commercial installation only and is not intended for home use.

### SERVICE CONNECTIONS:

(P1) ½" ID (13 mm) and ¾" OD (19 mm) rear gas connection

MODEL	WIDTH	DEPTH	OVERALL HEIGHT	WORKING HEIGHT	TANK SIZE	BTU/HR.	FRY COMP. CAPACITY	NO. OF CHICKEN PIECES*	APPROX. SHIP. WT.
1HG65M	21"	30¼"	47⅞"	36¼"	19½" x 14"	150,000	65 - 70 lbs.	56	275 lbs.

\*Based on 5 birds cut into 8 pieces

As continued product improvement is a policy of Hobart, specifications are subject to change without notice.