



HEATED ZONE MERCHANDISER

Models HZMH-24, -30, -36, -42, -48, -54, -60 HZMH-24D, -30D, -36D, -42D, -48D, -54D, -60D
 HZMS-24, -30, -36, -42, -48, -54, -60 HZMS-24D, -30D, -36D, -42D, -48D, -54D, -60D

The new energy-efficient Hatco Heated Zone Merchandiser safely holds hot packaged food in a smartly designed display that attracts customers. Energy costs are reduced by utilizing Spot On™ technology - instant-on overhead elements that are off until a food product is placed on the shelf, compared to other heated merchandisers that stay on full power 100% of the time. Each shelf has multiple heat zones for maximum efficiency. Due to the intensity of the overhead heating elements, Hatco recommends food packaging that can withstand high temperatures.

FLEXIBILITY

This warmer offers the convenience of self-serve and the efficiency of kitchen-to-server holding.

Available in slant or horizontal shelves, the Heated Zone Merchandising Warmers are offered in both single and dual shelf models. Choose from *Designer* colors, or in standard Bold Black to blend the Zone Merchandiser with any décor.

QUALITY

The following features assure the finest performance for years to come:

- New Spot On technology! Overhead heat is on only when product is present in that zone. Base heat goes from energy saving mode to thermostatically controlled
- New LCD control display for continuous zone monitoring
- Side glass is hinged to the post, and can swing out for easy cleaning. A magnetic catch holds glass in place during standard use.
- These warmers feature a thermostatically-controlled, hardcoated heated base, overhead ribbon elements, and a cord and plug set
- Channel dividers are held in place by magnets, giving the unit more heated surface
- LED lighting on each shelf for illumination, and optional LED accent lighting in support posts

Heated Zone Merchandiser with Spot-ON™ technology

Equipment
On Signage Program
Hatcographics.com



Model HZMS-36D with optional LED accent lighting in support posts

Model Width	Total Zone Space x 21.75"D (552 mm)	Divider Rods Provided	Zone Width	Zones per Shelf
24	20.08"W (510 mm)	3 Rods per Shelf	20.08"W (510 mm)	2
30	24.78"W (629 mm)	4 Rods per Shelf	12.39"W (315 mm)	4
36	30.74"W (780 mm)	4 Rods per Shelf	15.37"W (390 mm)	4
42	36.74"W (933 mm)	6 Rods per Shelf	18.37"W (467 mm)	4
48	42.74"W (1085 mm)	6 Rods per Shelf	21.37"W (543 mm)	4
54	47.52"W (1207 mm)	6 Rods per Shelf	15.84"W (402 mm)	6
60	53.52"W (1359 mm)	9 Rods per Shelf	17.84"W (453 mm)	6

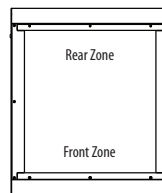

HZM-24

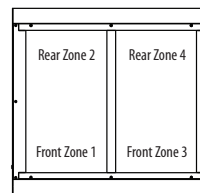

HZM-30

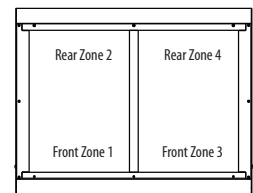

HZM-36

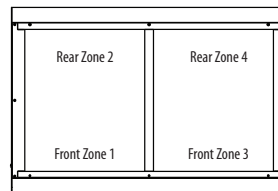

HZM-42

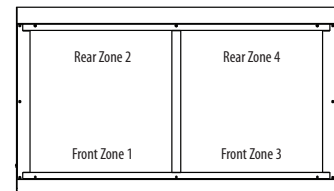

HZM-48

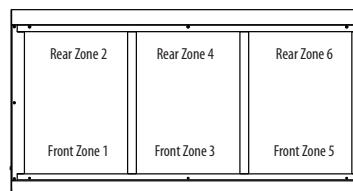

HZM-54

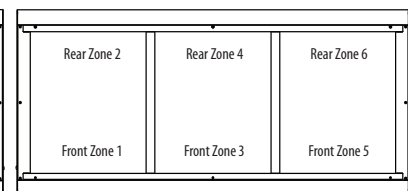

HZM-60



HEATING ELEMENTS GUARANTEED AGAINST
BURNOUT AND BREAKAGE FOR ONE YEAR.

HATCO CORPORATION P.O. Box 340500 Milwaukee, WI 53234-0500 U.S.A.
 (800) 558-0607 • (414) 671-6350 • Fax (800) 543-7521 • Int'l. Fax (414) 671-3976
 www.hatcocorp.com • E-mail: equipsales@hatcocorp.com

Form No. HZM Spec Sheet

Printed in U.S.A.
May 2011



HEATED ZONE MERCHANDISER

Models HZMH-24, -30, -36, -42, -48, -54, -60 HZMH-24D, -30D, -36D, -42D, -48D, -54D, -60D
 HZMS-24, -30, -36, -42, -48, -54, -60 HZMS-24D, -30D, -36D, -42D, -48D, -54D, -60D

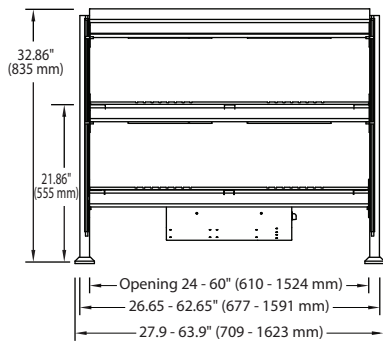

FRONT VIEW
Horizontal

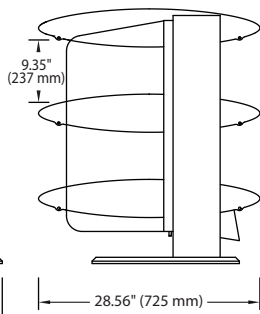

SIDE VIEW
Horizontal

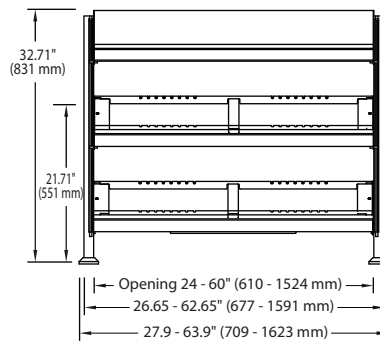

FRONT VIEW
Slant

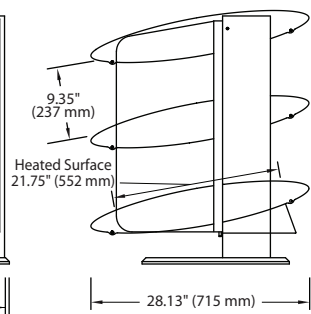

SIDE VIEW
Slant

SPECIFICATIONS Horizontal Models

	Model	Watts	Voltage	No. of Heat Zones
Single Shelf	HZMH-24	752	120	2
	HZMH-30	1353	120	4
	HZMH-36	1406	120	4
	HZMH-42	1458	120	4
	HZMH-48	1508	120	4
	HZMH-54	2109	120, 120/208-240	6
	HZMH-60	2161	120, 120/208-240	6
Dual Shelf	HZMH-24D	1504	120	4
	HZMH-30D	2706	120/208-240	8
	HZMH-36D	2811	120/208-240	8
	HZMH-42D	2915	120/208-240	8
	HZMH-48D	3015	120/208-240	8
	HZMH-54D	4218	120/208-240	12
	HZMH-60D	4322	120/208-240	12

Slant Models

	Model	Watts	Voltage	No. of Heat Zones
Single Shelf	HZMS-24	752	120	2
	HZMS-30	1353	120	4
	HZMS-36	1406	120	4
	HZMS-42	1458	120	4
	HZMS-48	1508	120	4
	HZMS-54	2109	120, 120/208-240	6
	HZMS-60	2161	120, 120/208-240	6
Dual Shelf	HZMS-24D	1504	120	4
	HZMS-30D	2706	120/208-240	8
	HZMS-36D	2811	120/208-240	8
	HZMS-42D	2915	120/208-240	8
	HZMS-48D	3015	120/208-240	8
	HZMS-54D	4218	120/208-240	12
	HZMS-60D	4322	120/208-240	12

DIMENSIONS

Horizontal Models (HZMH) –

Single: 27.9" - 63.9"W x 28.56"D x 21.86"H (709-1623 x 725 x 555 mm).

Dual: 27.9" - 63.9"W x 28.56"D x 32.86"H (709-1623 x 725 x 835 mm).

Slant Models (HZMS) –

Single: 27.9" - 63.9"W x 28.13"D x 21.71"H (709-1623 x 715 x 551 mm).

Dual: 27.9" - 63.9"W x 28.13"D x 32.71"H (709-1623 x 715 x 831 mm).

CORD LOCATION

Back center of base, on left side of control box.

PLUG CONFIGURATIONS

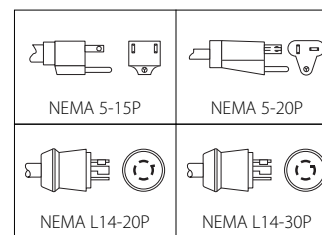

OPTIONS (NOT FOR RETROFIT)

- Designer Colors: Warm Red, Black, Gray Granite, White Granite, Navy Blue, Hunter Green, or Antique Copper. Bold Black is standard
- LED accent lights for support posts
- Flip-up Doors for front or back (not compatible with accessory sneeze guards in same opening)

- Sneeze Guards for front or back (not compatible with accessory flip-up doors in same opening)

ACCESSORIES

- Additional Stainless Steel Divider Rods

PRODUCT SPECS

Designer Merchandising Warmer

The Heated Zone Merchandising Warmer shall be model ... as manufactured by the Hatco Corporation, Milwaukee, WI 53234 U.S.A.

With 24/7 service (U.S. and Canada only), the warmer shall be rated at ... watts, ... volts, and be ... inches (millimeters) in overall width. It shall consist of a

thermostatically-controlled heated base, infrared heat from above, full-view tempered glass sides, and LED display lights. The merchandiser shall have fast heating infrared ribbon elements and will have a cord with plug attached.

Accessories shall include additional stainless steel dividers rods.

HATCO CORPORATION P.O. Box 340500 Milwaukee, WI 53234-0500 U.S.A. • (800) 558-0607 • (414) 671-6350
 Fax (800) 543-7521 • Int'l. Fax (414) 671-3976 • www.hatcocorp.com • E-mail: equipsales@hatcocorp.com