



FLAV-R-SAVOR® HEATED AIR CURTAIN CABINETS

Models FSHAC-2, -3 FSHACH-2, -3, -2PT

The Hatco Flav-R-Savor® Heated Air Curtain Cabinet effectively and safely holds hot food hot without the use of doors, allowing immediate access to product. Warm air at the front of the cabinet is forced downward, through ducts above the opening, forming a "curtain" of heated air. A portion of the heated air is drawn toward the rear through special perforations on the back wall, warming each pan.

FLEXIBILITY

The patented Hatco Heated Air Curtain Cabinet is ideal for holding wrapped product like tortillas, burritos, and ribs, as well as product on sheet pans like biscuits, chicken, hamburger patties, pizza, and baked potatoes. Holding temperatures range from 80°F to 175°F (27°-79°C).

Choose from 2-pan and 3-pan units, single opening or pass-through, with or without humidity. Humidified models can be filled manually or with the auto-fill feature.

The standard units hold half-size sheets pans (one per shelf) and the 2-pan pass-through model accommodates two full size sheet pans.

QUALITY

The following features assure the finest performance for years to come:

- Heated Air Curtain Cabinet effectively and safely holds hot food hot without the use of doors, allowing immediate access to product.
- 2-pan and 3-pan units available, with or without humidity.
- The standard units hold half-size sheets pans (one per shelf) and the 2-pan pass-through model accommodates two full size sheet pans.



Model FSHACH-3
Patented



Model FSHACH-2PT
Pass-through with
accessory food pans
Patented



Model FSHACH-2
with accessory food pans
Patented

BLANKET ELEMENTS GUARANTEED AGAINST
BURNOUT AND BREAKAGE FOR ONE YEAR.



HATCO CORPORATION P.O. Box 340500 Milwaukee, WI 53234-0500 U.S.A.
(800) 558-0607 • (414) 671-6350 • Fax (800) 543-7521 • Int'l. Fax (414) 671-3976
www.hatcocorp.com • E-mail: equipsales@hatcocorp.com

Form No. FSHAC Spec Sheet

Printed in U.S.A.
February 2013



FLAV-R-SAVOR® HEATED AIR CURTAIN CABINETS

Models FSHAC-2, -3 FSHACH-2, -3, -2PT

Models FSHAC-2 & FSHACH-2

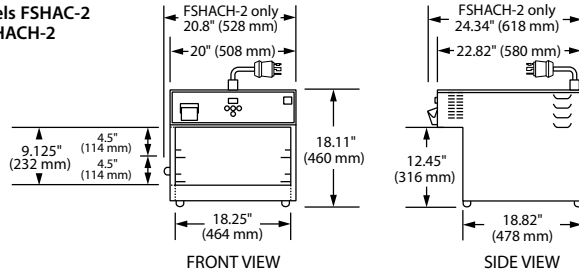

Model FSHACH-2PT

(shown with accessory 4" (102 mm) legs)

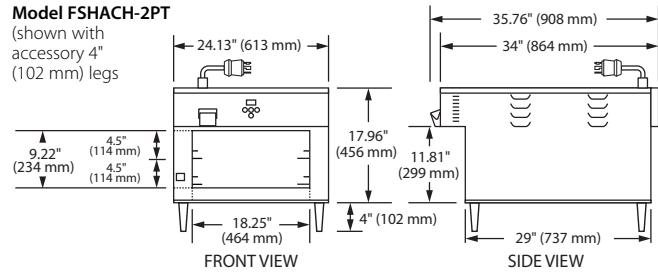

Models FSHAC-3 & FSHACH-3

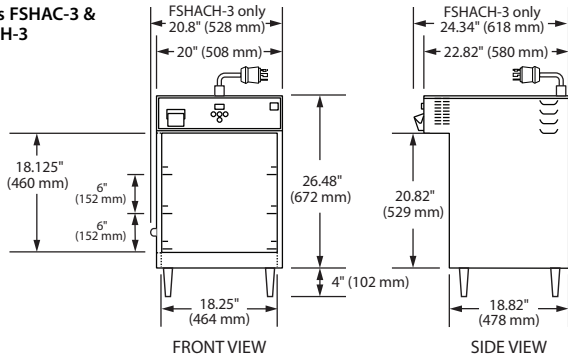

DIMENSIONS

FSHAC-2: 20"W x 22.82"D x 18.11"H (508 x 580 x 460 mm).
 FSHACH-2: 20.8"W x 24.34"D x 18.11"H (528 x 618 x 460 mm).
 FSHAC-3: 20"W x 22.82"D x 30.48"H* (508 x 580 x 774 mm).
 FSHACH-3: 20.8"W x 24.34"D x 30.52"H* (528 x 618 x 775 mm).
 FSHACH-2PT: 24.13"W x 35.76"D x 21.96"H* (613 x 908 x 558 mm).
 * Including 4" (102 mm) legs.

Cabinet Openings:

FSHAC-2, FSHACH-2: 18.25"W x 9.125"H (464 x 232 mm).
 FSHAC-3, FSHACH-3: 18.25"W x 18.125"H (464 x 460 mm).
 FSHACH-2PT: 18.25"W x 9.22"H (464 x 234 mm).

Water Tank Capacity (Humidified models only):

FSHACH-2, -3: 2 1/4 gallons (9 liters).
 FSHACH-2PT: 3 gallons (11 liters).

VOLTAGE

FSHAC-2: 120 volts, 60 Hz, 1850 watts, 15.4 amps (uses NEMA 5-20P).
 FSHAC-2, -3: 120/208 volts, 60 Hz, 1877 watts, 9.0 amps (uses NEMA L14-20P).
 FSHACH-2, -3: 120/208 volts, 60 Hz, 2950 watts, 14.2 amps (uses NEMA L14-20P).
 FSHACH-2PT: 120/208 volts, 60 Hz, 4952 watts, 23.8 amps (uses NEMA L14-30P). 208 volts, 60 Hz, 4952 watts, 23.8 amps (uses NEMA L6-30P).

CORD LOCATION

FSHAC-2, -3, FSHACH-2, -3: Top of unit towards the back, middle.
 FSHACH-2PT: Top of unit towards the back, left side.

PLUG CONFIGURATIONS

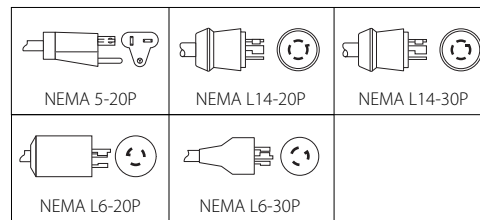

SPECIFICATIONS

Standard Models

Model	Type	Shipping Weight
FSHAC-2	2-Tier Warmer with Air Curtain	100 lbs. (45 kg)
FSHAC-3*	3-Tier Warmer with Air Curtain	115 lbs. (52 kg)

Humidified Models[▲]

Model	Type	Shipping Weight
FSHACH-2	Humidified 2-Tier Warmer with Air Curtain	100 lbs. (45 kg)
FSHACH-3*	Humidified 3-Tier Warmer with Air Curtain	115 lbs. (52 kg)
FSHACH-2PT	Humidified Pass-Through 2-Tier Warmer with Air Curtain	150 lbs. (68 kg)

* Includes 4" (102 mm) legs.

▲ Standard with auto-fill, relative humidity level maximum is 27%.

WATER QUALITY REQUIREMENTS

Water supply in excess of 3.0 grains of hardness per gallon (GPG) (.75 grains of hardness per liter) must be treated and softened before being used. Water containing over 3.0 GPG (.75 GPL) will decrease the efficiency and reduce the operating life of the unit.

Note: Product failure caused by liming or sediment buildup is not covered under warranty.

ACCESSORIES

- Back-to-Back Mounting on a Single Base (FSHAC-2 and FSHACH-2 models only) (add 1" (25 mm) to height)
- 4" (102 mm) legs (Standard on 2-Pan Pass-Through and 3-Pan models)

- Slant Rack
- Rib Rack
- Food Pans

PRODUCT SPECS

Heated Air Curtain

The Heated Air Curtain Cabinet shall be a Flav-R-Savor® Model ... as manufactured by the Hatco Corporation, Milwaukee, WI 53234 U.S.A.

With 24/7 service (U.S. and Canada only), the Heated Air Curtain shall be rated at ... watts, ... volts, and be ... inches (millimeters) in overall width.

It shall consist of a powdercoated steel housing, stainless steel front panel, and metal sheathed heating elements. Heated Air Curtain features easy-to-use digital controls, an on-off switch, and 6' (1829 mm) cord with plug.

HATCO CORPORATION P.O. Box 340500 Milwaukee, WI 53234-0500 U.S.A. • (800) 558-0607 • (414) 671-6350
Fax (800) 543-7521 • Int'l. Fax (414) 671-3976 • www.hatcocorp.com • E-mail: equipsales@hatcocorp.com