



FLAV-R-FRESH® IMPULSE DISPLAY CABINETS

Models FDW-1, FDW-1X, FDW-2, FDW-2X

Hatco has a profitable way to create impulse food sales with the small Flav-R-Fresh Holding and Display Cabinet. Controlled moisturized heat lets you display and hold hot foods longer using minimum counter space.

FLEXIBILITY

The Hatco Flav-R-Fresh has separate heat and humidity controls to keep crisp foods crisp and moist foods moist, not just for minutes but for hours. It holds everything from hot pretzels to 15" (381 mm) pizzas, croissants to bagels, and even hot dogs and meat pies.

Electrical components, controls, and water reservoir are located at the top for easy access. A temperature monitor indicates the cabinet temperature. A red light indicates a low water level and a green light shows the humidity cycle.

Models with two doors are available for pass-through convenience and a variety of merchandising racks help enhance food appeal.

The Hatco Flav-R-Fresh is ideal for restaurants, pizzerias, convenience stores, concession stands, snack bars, and kiosks.

QUALITY

The following features assure the finest performance for years to come:

- The stainless steel display cabinet features tempered glass sides and door for full-view display.
- Shatter-resistant incandescent light enhances food appeal while safe-guarding food products from bulb breakage.
- A large single door provides fast access to food racks.
- Food decals and merchandising signs are available to help promote product.



Model FDW-1 with rotating 4-tier rack and accessory decals and pans



Model FDW-1X with stationary 4-shelf multi-purpose rack

Custom Food Decals & Merchandising Signs



Designed to attract attention and stimulate sales, Flav-R-Fresh offers eye-catching food decals (specify Pizza, Chicken, Pretzel, or Biscuits/Croissants). Or choose optional PIZZA or PRETZEL display signs in bright red with yellow letters.

METAL SHEATHED AIR HEATING ELEMENTS
GUARANTEED AGAINST BURNOUT AND BREAKAGE
FOR TWO YEARS.



HATCO CORPORATION P.O. Box 340500 Milwaukee, WI 53234-0500 U.S.A.
(800) 558-0607 • (414) 671-6350 • Fax (800) 543-7521 • Int'l. Fax (414) 671-3976
www.hatcocorp.com • E-mail: equipsales@hatcocorp.com

Form No. FDW Spec Sheet

Printed in U.S.A.
September 2007



FLAV-R-FRESH® IMPULSE DISPLAY CABINETS

Models FDW-1, FDW-1X, FDW-2, FDW-2X

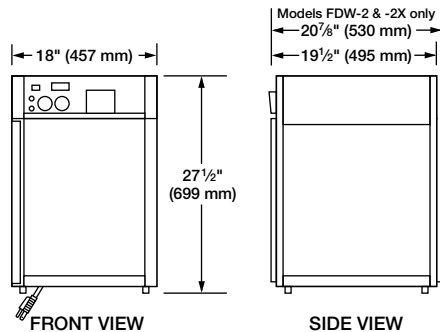

DIMENSIONS

FDW-1, FDW-1X: 18" W x 19 1/2" D x 27 1/2" H
(457 x 495 x 699 mm).

FDW-2, FDW-2X: 18" W x 20 7/8" D x 27 1/2" H
(457 x 530 x 699 mm).

Cabinet Opening: 15 1/2" W x 19 1/4" H
(394 x 489 mm).

VOLTAGE

120 volts, 60 Hz, 1470 watts, 12.3 amps (uses
NEMA 5-15P, NEMA 5-20P – Canada).

Export voltages available.

CORD LOCATION

Facing controls, underneath left corner.

PLUG CONFIGURATIONS

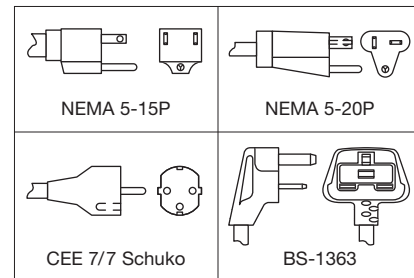

SPECIFICATIONS

Model*	Type	Rack Style	Shipping Weight
FDW-1	1 Door	Circle Rack† with Rack Motor	80 lbs. (36 kg)
FDW-1X	1 Door	Multi-Purpose Rack without Rack Motor	82 lbs. (37 kg)
FDW-2	2 Doors	Circle Rack† with Rack Motor	86 lbs. (39 kg)
FDW-2X▲	2 Doors	Multi-Purpose Rack without Rack Motor	88 lbs. (40 kg)

* Models FDW-1 and FDW-2 include rack motor. Models with "X" designator do not have revolving display and are NOT available for retrofit.

† Pretzel Rack available in lieu of Circle Rack.

▲ Accommodates half-size sheet pans.

WATER QUALITY REQUIREMENTS

Water supply in excess of 3.0 grains of hardness per gallon (GPG) (.75 grains of hardness per liter) must be treated and softened before being used. Water containing over 3.0 GPG (.75 GPL) will decrease the efficiency and reduce the operating life of the unit.

Note: Product failure caused by liming or sediment buildup is not covered under warranty.

OPTIONS (NOT FOR RETROFIT)

- Designer Colors: Warm Red, Black, Gray Granite, White Granite, Navy Blue, Hunter Green
- Self-Closing Doors

ACCESSORIES

- 4-Tier Circle Rack (Requires motorless rack coupling on -X models)
- 4-Shelf Multi-Purpose Rack (Each shelf 13 5/8" W x 12 5/8" D (346 x 321 mm))
- 4-Shelf Angle Rack (Each shelf 14" W x 14 1/2" D (356 x 368 mm))
- 3-Tier Pretzel Tree (Requires motorless rack coupling on -X models)
- Motorless Rack Coupling (For -X models only)
- 14" (356 mm) Diameter Pizza Pan
- 15" (381 mm) Diameter Pizza Pan
- Half-size Sheet Pan 18" x 13" (457 x 330 mm)
- 4" (102 mm) Adjustable Legs
- Merchandising Signs (3 per set)
 - Pizza
 - Pretzel
- Custom Food Decals (3 per set)
 - Pizza, Chicken, Pretzel, or Croissants/Biscuits

Display Rack Selection

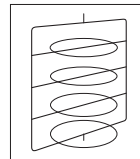

4-Tier Circle Rack
Model FDW4TCR
Rack Opening:
3 1/4" (83 mm)
Maximum
15" (381 mm)
diameter pans

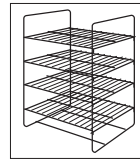

4-Shelf Multi-Purpose Rack*
Model FDW4SMP
Rack Opening:
3 1/2" (89 mm)

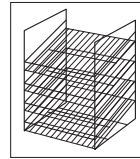

4-Shelf Angle Rack
Model FDW4SAR
Rack Opening:
3 3/4" (95 mm)

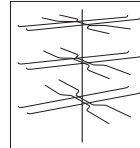

3-Tier Pretzel Tree
Model FDW3TPT
Rack Opening:
5 1/16" (148 mm)

* Accommodates half-size sheet pans (Not included).

PRODUCT SPECS

Impulse Display Cabinet

The humidity controlled Impulse Display Cabinet shall be a Flav-R-Fresh® Modelrated atvolts andwatts, as manufactured by the Hatco Corporation, Milwaukee, WI 53234 U.S.A.

With 24/7 parts and service assistance (U.S. and Canada only), the cabinet shall havedoor(s), tempered glass sides,

stationary rack (or revolving display), and incandescent display light. It shall include a water reservoir, humidity selector switch, temperature selector dial, on-off switch, and indicating lights. A 6' (1829 mm) cord with plug shall be attached.

Accessories shall include merchandising racks, display sign(s), and food graphic decals.

HATCO CORPORATION P.O. Box 340500 Milwaukee, WI 53234-0500 U.S.A. • (800) 558-0607 • (414) 671-6350
Fax (800) 543-7521 • Int'l. Fax (414) 671-3976 • www.hatcocorp.com • E-Mail: equipsales@hatcocorp.com