



Specifications

F.O.B Sedalia, Missouri 65301



E-3-CBSS shown with optional maple cutting board

OPTIONS:

- 10" wide maple carving board, stainless steel brackets
- 14 gauge tops
- Heated base module
- 3-phase wiring
- Sliding Doors
- Cord and plug
- Adaptor plates
- Casters (add cord and plug), 5" swivel with locks
- Casters (add cord and plug), 5" swivel no lock
- Veneered panels
- Powder coat paint colors
- 1/2" poly cutting surface added to stainless steel carving board
- Foodshields
- Trayslides and carving boards

AGENCY LISTINGS:



DUKE MANUFACTURING CO.
 2305 N. Broadway
 St. Louis, MO 63102

800.735.3853 Toll Free
314.231.5074 Fax
www.dukemfg.com

Approval Stamp(s):

PRODUCT INFORMATION:

PROJECT: _____
 ITEM: _____
 QUANTITY: _____

MODEL:

Thurmaduke® Steamtables Hot Food Units - Electric - Standard

- E-2-CBPG/E-2-CBSS 2 top openings
- E-3-CBPG/E-3-CBSS 3 top openings
- E-4-CBPG/E-4-CBSS 4 top openings
- E-5-CBPG/E-5-CBSS 5 top openings
- E-6-CBPG/E-6-CBSS 6 top openings

TOP:

- One piece. 16 gauge, 300 Series stainless steel
- Top openings die - stamped. 12" x 20"

HEAT COMPARTMENTS:

- Sealed wells with drains copper manifolds and brass master valve
- 750 watt element at 120, 208, or 240 volt / single or 3-phase
- Robertshaw thermostat w/indicator light per section
- Master toggle switch w/indicator light - entire unit
- 12" x 20" stainless steel liner, 6-1/2" deep

BODY AND INTERIOR SHELF:

- 300 Series stainless steel or paint grip steel
- End panels
- 6" polished stainless steel adjustable legs
- 300 Series stainless steel control panel
- Wire knob guards

SHORT FORM SPECIFICATIONS:

Thurmaduke® Steamtables - Hot Food - Electrical - Standard. Top shall be 16ga, 300 series Stainless Steel flanged down edges, flush at ends, 20ga s/s body & under shelf, with 15-1/2" opening for storage, s/s sealed well pan openings to be 12" x 20"x 6-1/2" deep, die-stamped, drains, copper manifolds, one valve, Robertshaw thermostats, unit wired to master toggle w/ indicator, 6" Stainless adjustable legs.



MODEL:
Thurmaduke® Steamtables
Hot Food Units - Electric - Standard

- E-2-CBPG/E-2-CBSS 2 top openings
- E-3-CBPG/E-3-CBSS 3 top openings
- E-4-CBPG/E-4-CBSS 4 top openings
- E-5-CBPG/E-5-CBSS 5 top openings
- E-6-CBPG/E-6-CBSS 6 top openings

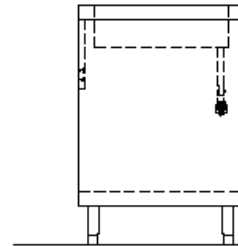
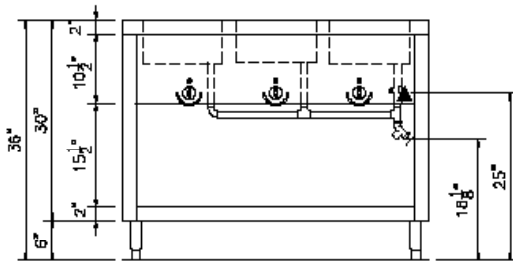
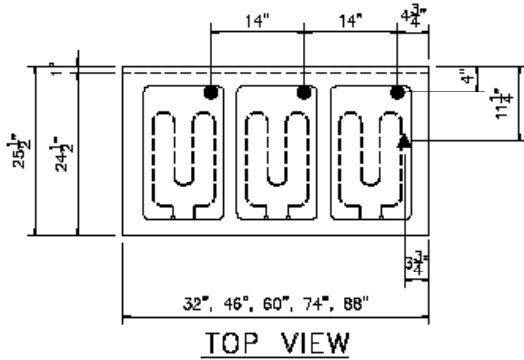

LEGEND	
▲	- ELECTRICAL CONNECTION
●	- DRAIN LOCATION

FRONT VIEW

RIGHT SIDE VIEW

DIMENSIONS:

FREIGHT CLASS: 150

Model		Length		Width		Height		Top Openings	Cube ft. Crated	Weight	
Enameled	Stainless	in.	cm	in.	cm	in.	cm			lbs.	kg
E-2-CBPG	E-2-CBSS	32	81.3	25-1/2	64.8	36	91.4	2	28.1	210	95.5
E-3-CBPG	E-3-CBSS	46	116.8	25-1/2	64.8	36	91.4	3	39.6	264	120.0
E-4-CBPG	E-4-CBSS	60	152.4	25-1/2	64.8	36	91.4	4	51.2	344	156.4
E-5-CBPG	E-5-CBSS	74	188.0	25-1/2	64.8	36	91.4	5	62.3	433	196.8
E-6-CBPG	E-6-CBSS	88	223.5	25-1/2	64.8	36	91.4	6	74.3	527	239.6

ELECTRICAL SPECIFICATIONS:

Cord & NEMA plug NOT included

Model	120 Volt - 750 watt elements			208 Volt - 750 watt elements			240 Volt - 750 watt elements		
	Watts	Amps	NEMA	Watts	Amps	NEMA	Watts	Amps	NEMA
E-2-CBPG/SS	1500	12.5	5-15	1500	7.2	6-20	1500	6.3	6-20
E-3-CBPG/SS	2250	18.8	L5-30	2250	10.8	6-20	2250	9.4	6-20
E-4-CBPG/SS	3000	25.0	5-50	3000	14.4	6-20	3000	12.5	6-20
E-5-CBPG/SS	3750	31.3	5-50	3750	18.0	L6-30	3750	15.9	6-20
E-6-CBPG/SS	N/A			4500	21.6	L6-30	4500	18.8	L6-30

DUKE MANUFACTURING CO.
 2305 N. Broadway
 St. Louis, MO 63102



800.735.3853 Toll Free
 800.231.1130 In Missouri
 314.231.5074 Fax
 www.dukemfg.com

Specification subject to change