

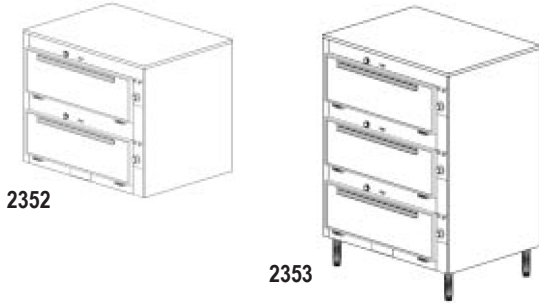

Specifications

F.O.B Sedalia, Missouri 65301



OPTIONS:

- Enclosed base - 6" high
- Cord and plug - 8'
- Casters - 5" polyurethane, 2 swivel w/brakes 2 rigid
- Push bar
- Bumpers - stainless steel
- Door Panels - laminated plastic
- Additional pair 3" angle slides
- Door locks
- Legs - for 2352 and 2352P models
- 440-480V Circuit
- Celsius thermometer in lieu of Fahrenheit
- 208V/1Ph; 208V/3Ph; 240V/1 PH; 240/3PH

AGENCY LISTING:



DUKE MANUFACTURING CO.
 2305 N. Broadway
 St. Louis, MO 63102

800.735.3853 Toll Free
 314.231.5074 Fax
 www.dukemfg.com

Approval Stamp(s):

PRODUCT INFORMATION:

PROJECT: _____
 ITEM: _____
 QUANTITY: _____

MODEL:

Thermotainer Food Holding Cabinets - "C" Series 9"H x 29"W x 23-1/2" D Compartments

- 2352** Reach-In 1 thermostat per compartment , w/o legs
- 2352P** Pass-Thru 1 thermostat per compartment , w/o legs
- 2353** Reach-In 1 thermostat per compartment , w/ legs
- 2353P** Pass-Thru 1 thermostat per compartment , w/ legs

BODY:

- Heavy gauge stainless steel, all panels except bottom
- Shell welded to interior
- Die-stamped compartment openings

DOORS:

- Stainless steel, die-stamped, embossed front
- Ribbed Interior
- Reinforced for mounting hardware
- Insulated with fiberglass
- Spring hinges die-stamped, with built-in-stop externally adjustable, completely concealed

COMPARTMENT:

- Heavy gauge stainless steel
- Rounded corners
- Stainless steel studs for angle slides at 3 levels
- (4) removable, adjustable, stainless steel, 3" angled slide pairs
- Removable liner for inspection and maintenance

ELECTRICAL CONTROLS:

- Recessed thermostat w/built-in On-Off switch
- Heat range 100° - 300° and dial thermometer
- Pilot lights
- Recessed connection box
- Removable access panel

DAMPERS:

- 2-position sliding type
- Controlled by push buttons
- Compartments individually controlled

INSULATION:

- Body fully insulated with 1-1/2" fiberglass

HEATING ELEMENTS:

- Sheath type strip heaters, 120 Volt, 1 Phase
- Removable compartment for ease of access to heating elements.

LEGS: For 2353 and 2353P models only

- Stainless steel die-stamped adjustable - 6" high

SHORT FORM SPECIFICATIONS:

Duke Thermotainers Food Holding Cabinets. Models 2352/2352P constructed with two (2) compartments. Models 2353/2353P to have three (3) compartments. Compartments 9"H x 29"W x 23-1/2"D. Each compartment to have four (4) pairs of removable stainless steel slides. One thermostat per compartment. 100° - 300°F heat range with dial thermometer and 6" high stainless legs. Built-in installation - allow 1/4" tolerance greater than body width.



**THERMOTAINER FOOD HOLDING CABINETS - "C" SERIES
9"H x 29"W x 23-1/2"D COMPARTMENTS**

- 2352** Reach-In 1 thermostat per compartment, w/o legs
- 2352P** Pass-Thru 1 thermostat per compartment, w/o legs
- 2353** Reach-In 1 thermostat per compartment, w/ legs
- 2353P** Pass-Thru 1 thermostat per compartment, w/ legs

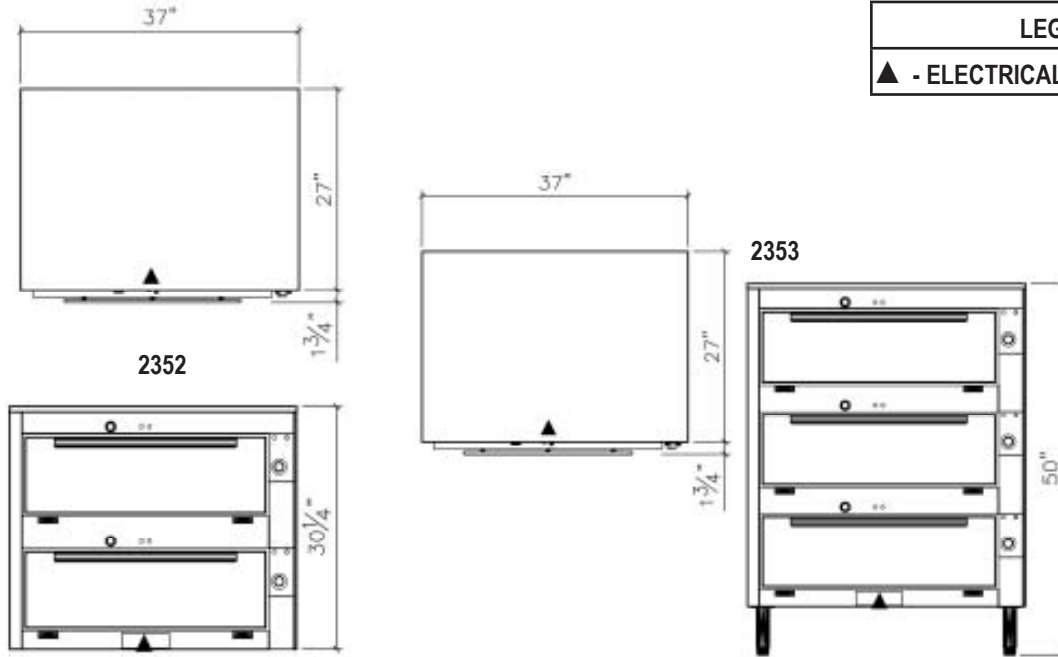

LEGEND	
▲	- ELECTRICAL CONNECTION

DIMENSIONS:

Freight Class: 100

Model	Width		Depth		Height		omp. Depth		Cube ft. crated	Weight	
	in.	cm.	in.	cm.	in.	cm.	in.	cm.		lbs.	kg.
2352	37	94.0	28-3/4	73.0	30-1/4	76.8	23-1/2	59.7	31.2	350	159.1
2352P	37	94.0	30-1/2	77.5	30-1/4	76.8	25-1/2	64.8	32.8	350	159.1
2353	37	94.0	28-3/4	73.0	50	127.0	23-1/2	59.7	47.3	350	250.0
2353P	37	94.0	30-1/2	77.5	50	127.0	25-1/2	64.8	49.3	350	250.0

ELECTRICAL SPECIFICATIONS: (Consult factory for 3-phase electrical requirements and other options.) 120V, 1Ph

Model	Connected Load
2352	2000 watts
2352P	2000 watts
2353	3000 watts
2353P	3000 watts

	2352/2352P	2353/2353P
Capacity w/standard slides	(12) 12" x 20" x 2" pans or (8) 12" x 20" x 4" pans or (4) 12" x 20" x 8" pans	(18) 12" x 20" x 2" pans or (12) 12" x 20" x 4" pans or (6) 12" x 20" x 8" pans

- 2352 Reach In - hinged doors on front only
- 2352P Pass Thru - hinged doors on front & back for pass-thru service
- 2353 Reach In - hinged doors on front only
- 2353P Pass Thru - hinged doors on front & back for pass-thru service



DUKE MANUFACTURING CO.
2305 N. Broadway
St. Louis, MO 63102

800.735.3853 Toll Free
800.231.1130 In Missouri
314.231.5074 Fax
www.dukemfg.com

Specification subject to change