



Specifications

F.O.B Sedalia, Missouri 65301



1353

OPTIONS:

- Enclosed base - 6" high
- Cord and plug - 8'
- Casters - 5" polyurethane, 2 swivel w/brakes 2 rigid
- Push bar
- Bumpers - stainless steel
- Door Panels - laminated plastic
- Additional pair 3" angle slides
- Door locks
- 440-480V Circuit
- Celsius thermometer in lieu of Fahrenheit
- 208V/1Ph; 208V/3Ph; 240V/1 PH; 240/3PH

AGENCY LISTING:



DUKE MANUFACTURING CO.
 2305 N. Broadway
 St. Louis, MO 63102

800.735.3853 Toll Free
 314.231.5074 Fax
 www.dukemfg.com

Approval Stamp(s):

PRODUCT INFORMATION:

PROJECT: _____
 ITEM: _____
 QUANTITY: _____

MODEL:

Thermotainer Food Holding Cabinets - "C" Series
9"H x 29"W x 23-1/2" D Compartments

- 1353** Reach-In 1 thermostat controls all 3 compartments, w/legs
- 1353P** Pass-Thru 1 thermostat controls all 3 compartments, w/legs

BODY:

- Heavy gauge stainless steel, all panels except bottom
- Shell welded to interior
- Die-stamped compartment openings

DOORS:

- Stainless steel, die-stamped, embossed front
- Ribbed Interior
- Reinforced for mounting hardware
- Insulated with fiberglass
- Spring hinges die-stamped, with built-in-stop externally adjustable, completely concealed

COMPARTMENT:

- Heavy gauge stainless steel
- Rounded corners
- Stainless steel studs for angle slides at 3 levels
- (4) removable, adjustable, stainless steel, 3" angled slide pairs
- Removable liner for inspection and maintenance

ELECTRICAL CONTROLS:

- Recessed thermostat w/built-in On-Off switch
- Heat range 100° - 300° and dial thermometer
- Pilot lights
- Recessed connection box
- Removable access panel

DAMPERS:

- 2-position sliding type
- Controlled by push buttons
- Compartments individually controlled

INSULATION:

- Body fully insulated with 1-1/2" fiberglass

HEATING ELEMENTS:

- Sheath type strip heaters, 120 Volt, 1 Phase
- Removable compartment for ease of access to heating elements.

LEGS:

- Stainless steel die-stamped adjustable - 6" high

SHORT FORM SPECIFICATIONS:

Duke Thermotainers Food Holding Cabinets. Models 1353/1353P constructed with three (3) compartment. Compartment 9"H x 29" W x 23-1/2" D. Each compartment to have four (4) pairs of removable stainless steel slides. One thermostat controls all compartments. 100° - 300° heat range and dial thermometer with 6" high stainless steel legs. Built-in installation - allow 1/4" tolerance greater than body with.



**THERMOTAINER FOOD HOLDING CABINETS - "C" SERIES
9"H x 29"W x 23-1/2"D COMPARTMENTS**

- 1353 Reach-In 1 thermostat controls all 3 compartments, w/ legs
- 1353P Pass-Thru 1 thermostat controls all 3 compartments, w/legs

LEGEND
▲ - ELECTRICAL CONNECTION

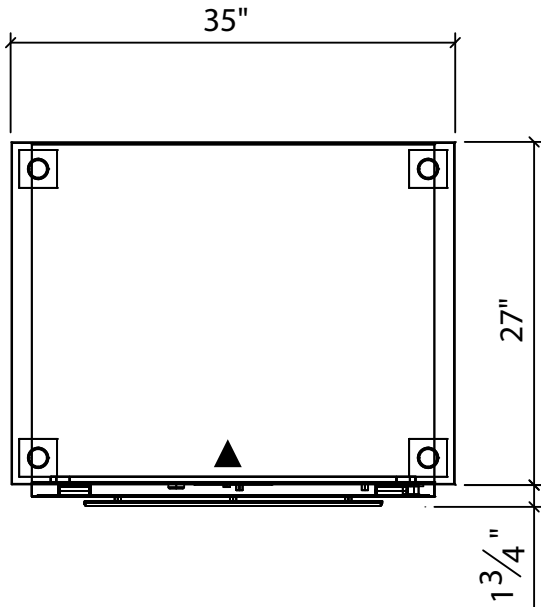

1353

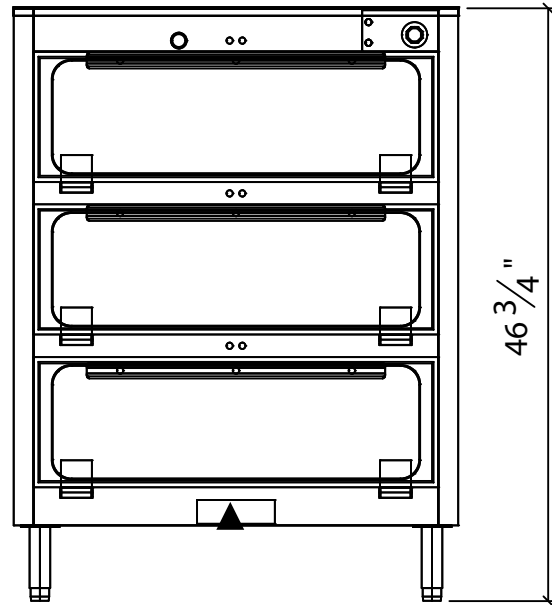

DIMENSIONS:

Freight Class: 100

Model	Width		Depth		Height		Comp. Depth		Cube ft. crated	Weight	
	in.	cm.	in.	cm.	in.	cm.	in.	cm.		lbs.	kg.
1353	35	88.9	28-3/4	73.0	46-3/4	118.8	23-1/2	59.7	42.5	500	227.3
1353P	35	88.9	30-1/2	77.5	46-3/4	118.8	25-1/2	64.8	44.8	550	250.

ELECTRICAL SPECIFICATIONS: (Consult factory for 3-phase electrical requirements and other options.) 120V, 1Ph

Model	Connected Load	1353/1353P	
1353	2000 watts	Capacity w/standard slides	(18) 12" x 20" x 2" pans or
1353P	2000 watts		(12) 12" x 20" x 4" pans or (6) 12" x 20" x 8" pans

- 1353 Reach In - hinged doors on front only
- 1353P Pass Thru - hinged doors on front & back for pass-thru service



DUKE MANUFACTURING CO.
 2305 N. Broadway
 St. Louis, MO 63102
 800.735.3853 Toll Free
 800.231.1130 In Missouri
 314.231.5074 Fax
 www.dukemfg.com

Specification subject to change