

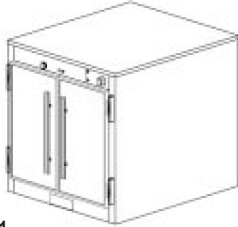

Specifications

F.O.B Sedalia, Missouri 65301



1551

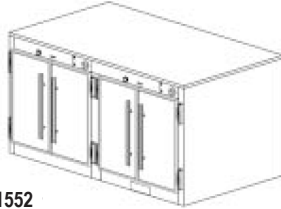

1552

OPTIONS:

- Enclosed base - 6" high
- Cord and plug - 8'
- Casters - 5" polyurethane, 2 swivel w/brakes 2 rigid
- Push bar
- Bumpers - stainless steel
- Door Panels - laminated plastic
- Additional pair 5" angle slides
- Door locks
- Legs
- 440-480V Circuit
- Celsius thermometer in lieu of Fahrenheit
- 208V/1Ph; 208V/3Ph; 240V/1 PH; 240/3PH

AGENCY LISTING:



DUKE MANUFACTURING CO.
 2305 N. Broadway
 St. Louis, MO 63102

800.735.3853 Toll Free
 314.231.5074 Fax
 www.dukemfg.com

Approval Stamp(s):

PRODUCT INFORMATION:

PROJECT: _____
 ITEM: _____
 QUANTITY: _____

MODEL:

Thermotainer Food Holding Cabinets - "E" Series 21"H x 22"W x 28-1/2" D Compartments

- 1551** Reach-In 1 thermostat control per compartment , w/o legs
- 1551P** Pass-Thru 1 thermostat control per compartment, w/o legs
- 1552** Reach-In 1 thermostat control per compartment , w/o legs
- 1552P** Pass-Thru 1 thermostat control per compartment, w/o legs

BODY:

- Heavy gauge stainless steel, all panels except bottom
- Shell welded to interior
- Die-stamped compartment openings

DOORS:

- Stainless steel Uni-Door construction
- Operate simultaneously, either opening or closing
- Overhead operating unit
- Automatic stop holds open position
- Spring hinges die-stamped, with built-in-stop externally adjustable, completely concealed

COMPARTMENT:

- Heavy gauge stainless steel
- Rounded corners
- Stainless steel studs for angle slides at 3 levels
- (4) removable, adjustable, stainless steel, 5" angled slide pairs
- Removable liner for inspection and maintenance

ELECTRICAL CONTROLS:

- Recessed thermostat w/built-in On-Off switch
- Heat range 100° - 300° and dial thermometer
- Pilot lights
- Recessed connection box
- Thermostat, pilot lights set in removable access panel

DAMPERS:

- 2-position sliding type
- Controlled by push buttons
- Compartments individually controlled

INSULATION:

- Body fully insulated with 1-1/2" fiberglass

HEATING ELEMENTS:

- Sheath type strip heaters, 120 Volt, 1 Phase
- Removable compartment for ease of access to heating elements.

SHORT FORM SPECIFICATIONS:

Duke Thermotainers Food Holding Cabinets. Models 1551/1551P constructed with one (1) compartments. Models 1552/1552P to have two (2) compartments. Compartments 21"H x 22"W x 28-1/2"D. Each compartments to have four (4) pairs of removable stainless steel slides. One thermostat per compartments. 100o - 300oF heat range with dial thermometer. Built-in installation - allow 1/4" tolerance greater than body width.

Thermotainer®

THERMOTAINER FOOD HOLDING CABINETS - "E" SERIES 21"H x 22"W x 28-1/2"D COMPARTMENTS

- 1551 Reach-In 1 thermostat per compartments, w/o legs
- 1551P Pass-Thru 1 thermostat per compartment, w/o legs
- 1552 Reach-In 1 thermostat per compartment, w/o legs
- 1552P Pass-Thru 1 thermostat per compartment, w/o legs

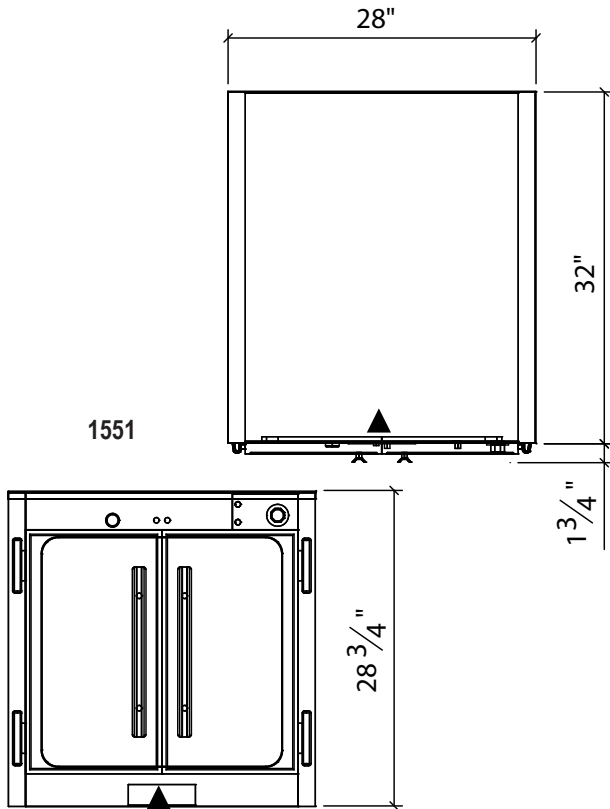

LEGEND
▲ - ELECTRICAL CONNECTION

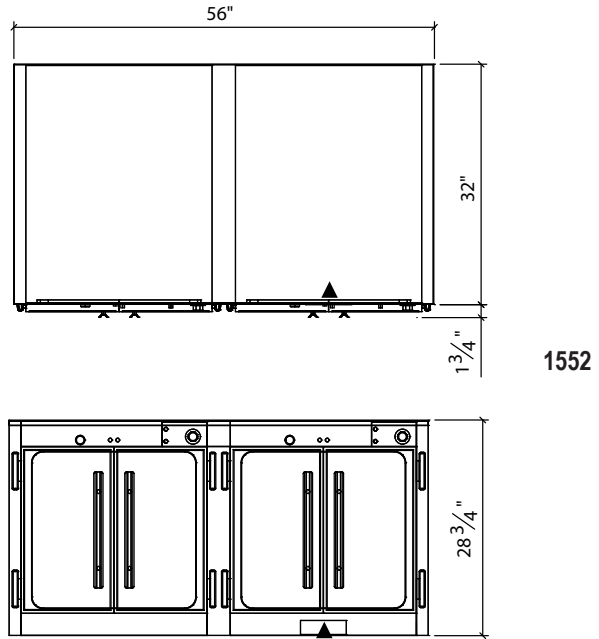

DIMENSIONS:

Freight Class: 100

Model	Width		Depth		Height		Comp. Depth		Cube ft. crated	Weight	
	in.	cm.	in.	cm.	in.	cm.	in.	cm.		lbs.	kg
1551	28	71.1	33-3/4	85.7	28-3/4	73.0	28-1/2	72.4	27.3	300	136.4
1551P	28	71.1	35-1/2	90.2	28-3/4	73.0	30-1/2	77.5	28.6	300	136.4
1552	56	142.2	33-3/4	85.7	28-3/4	73.0	28-1/2	72.4	49.8	600	272.7
1552P	56	142.2	35-1/2	90.2	28-3/4	73.0	30-1/2	77.5	52.1	600	272.7

ELECTRICAL SPECIFICATIONS: (Consult factory for 3-phase electrical requirements and other options.) 120V, 1Ph

Model	Connected Load		
1551	1500 watts		
1551P	1500 watts		
1552	3000 watts		
1552P	3000 watts		
		1551/1551P	1552/1552P
Capacity w/standard slides		(14) 12" x 20" x 2" pans or (8) 12" x 20" x 4" pans or (4) 12" x 20" x 8" pans (10) 18" x 26" bake sheets	(28) 12" x 20" x 2" pans or (16) 12" x 20" x 4" pans or (8) 12" x 20" x 8" pans (20) 18" x 26" bake sheets

- 1551 Reach In - hinged doors on front only
- 1551P Pass Thru - hinged doors on front & back for pass-thru service
- 1552 Reach In - hinged doors on front only
- 1552P Pass Thru - hinged doors on front & back for pass-thru service



DUKE MANUFACTURING CO.

2305 N. Broadway
St. Louis, MO 63102

800.735.3853 Toll Free
800.231.1130 In Missouri
314.231.5074 Fax
www.dukemfg.com

Specification subject to change