



Specifications

F.O.B Sedalia, Missouri 65301



116-118-L

OPTIONS:

- Provisions for sink mounted pot rack and /or shelf - **SK-1**
- Stainless steel pot rack, 2-bar, riser mounted - **SK-2**
- Stainless steel 12" wide shelf, riser mounted - **SK-3**
- Poly board sink cover - **SK-4**
- Carving board, 3/4" H.D. ploy - **SK-5**
- Z Bracket for wall attachment - **SK-7**
- Waste trough furnished w/2" deep removable basket - **SK-8**
- High backsplash, up to 6" higher - **SK-9**
- Extra drainboard length - **SK-10**
- Stainless steel sink cover - **SK-13**
- Installation of disposal cone - **SK-14**
- Installation of disposer collar - **SK-15**
- Faucet hold revision - **SK-16**
- Working height revision - **SK-17**
- Stainless steel undershelf - **SK-18**
- Flanged bullet feet, stainless steel - **SK-19**
- Provision for pot washer - **SK-20**
- Provision for Hatco Heater - **SK-21**
- Stainless steel welded leg assembly - **SK-22**
- Special size sink bowl - **SK-24**
- Sink preparation for Undercounter Dishwasher (24" drainboard) - **SK-25**
- Column cut-out - **SK-30**
- Splash cut-out - **SK-31**
- Scrap block installed - **SK-34**
- Drainboard or bowl sidesplash - **SK-49**
- Scrap trough - **SK-50**
- Pass-thru sill - **SK-51**
- Drainboard corner turn - **SK-54**
- Perforated basket to fit sink, stainless steel - **SK-57**
- Longitudinal crossrail - **SK-58**
- Vacuum breaker holes - **SK-61**
- Small switch bracket - **SK-62**
- Large control bracket - **SK-63**

AGENCY LISTING:



DUKE MANUFACTURING CO.
2305 N. Broadway
St. Louis, MO 63102

800.735.3853 Toll Free
314.231.1130 In Missouri
314.231.5074 Fax
www.dukemfg.com

Approval Stamp(s):

PRODUCT INFORMATION:

PROJECT: _____

ITEM: _____

QUANTITY: _____

MODEL:

Sinks - Deluxe - 16" x 21" x 11-1/2" D bowl, one drainboard

Model	Bowl Size
<input type="checkbox"/> 161-118 R or L	(1) 16" comp, w/18"L drainboard
<input type="checkbox"/> 161-124 R or L	(1) 16" comp, w/24"L drainboard
<input type="checkbox"/> 161-136 R or L	(1) 16" comp, w/36"L drainboard
<input type="checkbox"/> 162-118 R or L	(2) 16" comp, w/18"L drainboard
<input type="checkbox"/> 162-124 R or L	(2) 16" comp, w/24"L drainboard
<input type="checkbox"/> 162-136 R or L	(2) 16" comp, w/36"L drainboard
<input type="checkbox"/> 163-118 R or L	(3) 16" comp, w/18"L drainboard
<input type="checkbox"/> 163-124 R or L	(3) 16" comp, w/24"L drainboard
<input type="checkbox"/> 163-136 R or L	(3) 16" comp, w/36"L drainboard
<input type="checkbox"/> 164-118 R or L	(4) 16" comp, w/18"L drainboard
<input type="checkbox"/> 164-124 R or L	(4) 16" comp, w/24"L drainboard
<input type="checkbox"/> 164-136 R or L	(4) 16" comp, w/36"L drainboard

GENERAL:

- 16 gauge, 300 Series stainless steel
- Ground and polished welded parts
- Stainless steel legs and feet

SINK COMPARTMENTS:

- 16 gauge stainless steel fully welded fabricated bowls
- 11-1/2" water depth
- 1, 2, 3 and 4 bowl models available
- Special depth bowls
- Custom sizes available

BACKSPLASH:

- 8" high
- Custom heights available

SHORT FORM SPECIFICATIONS:

Duke Sinks - Deluxe - 16" x 21" x 11-1/2" D Bowl - ONE DRAIN-

BOARD. Shall be constructed of 16 gauge, 300 Series stainless steel with 1-3/4" rolled edge on front and both ends and 8" high backsplash, from top of roll, including 2" turnback at 45°, with 3/4" turn-up at wall side, as standard. All welded parts to be ground and polished to the original finish. All vertical and horizontal corners are covered on 1/4" or larger radius with intersections spherical and polished. In two or three compartment sinks, partitions shall have double wall. Bottom of each compartment shall be die-stamped with tapered grooves at least 1/4" deep at drain depression to permit complete drainage. Backsplash shall have 1" holes punched on 8" centers, 4" on center below top of splash (1-1/2" below turnback) to accommodate standard faucets. Holes are centered over partitions on two and three compartment sinks. Rolled edges and splash are continuous with edge and splash on sink, with all horizontal and vertical corners covered on 1/4" or larger radius. Drainboards (18", 24", 36" lengths) shall be welded integrally to sink. Sinks to be mounted on four 1-5/8" OD 16 gauge stainless steel tubular legs with adjustable stainless steel feet. Legs are mounted on stainless steel gussets.

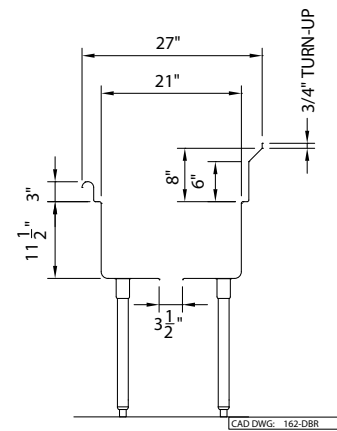
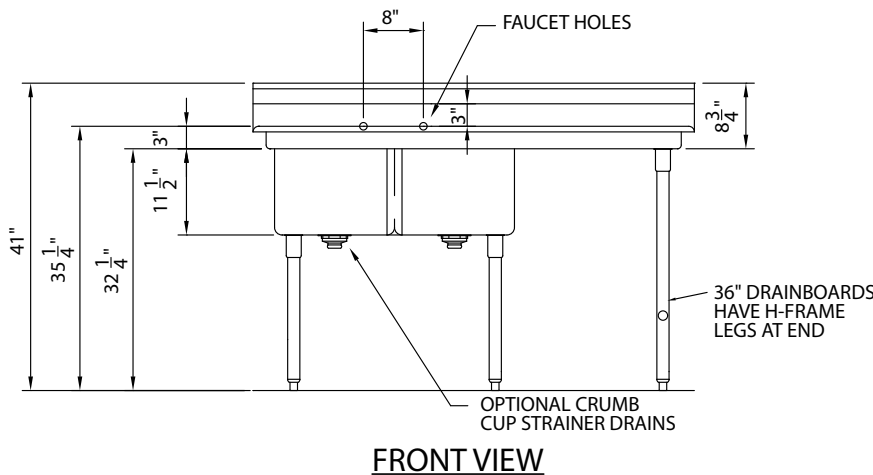
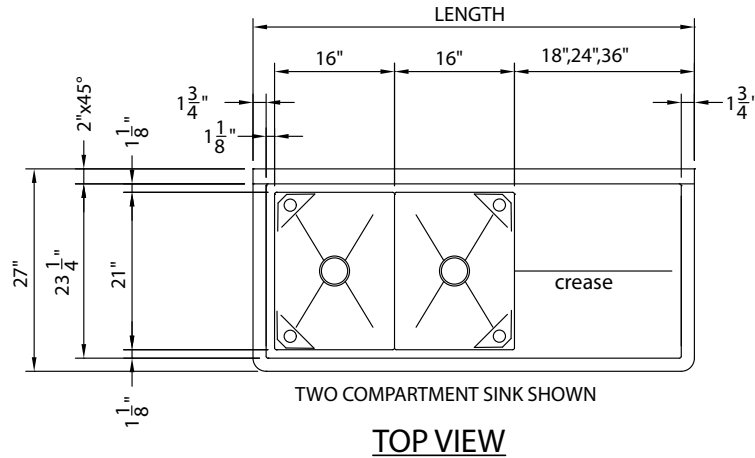

DUKE SINKS - DELUXE -16" x 21" x 11-1/2" D BOWL, ONE DRAINBOARD

- 161-118 R or L (1) 16" comp, w/18"L drainboard
- 161-124 R or L (1) 16" comp, w/24"L drainboard
- 161-136 R or L (1) 16" comp, w/36"L drainboard
- 162-118 R or L (2) 16" comp, w/18"L drainboard
- 162-124 R or L (2) 16" comp, w/24"L drainboard
- 162-136 R or L (2) 16" comp, w/36"L drainboard
- 163-118 R or L (3) 16" comp, w/18"L drainboard
- 163-124 R or L (3) 16" comp, w/24"L drainboard
- 163-136 R or L (3) 16" comp, w/36"L drainboard
- 164-118 R or L (4) 16" comp, w/18"L drainboard
- 164-124 R or L (4) 16" comp, w/24"L drainboard
- 164-136 R or L (4) 16" comp, w/36"L drainboard

DIMENSIONS:

Model	# Comp	Length		Depth		Height		Cube ft. crated	Weight	
		In	cm	in.	cm	in.	cm		lbs.	kg
161-118 R or L	1	37	94.0	27	78.7	41	104.1	37.8	65	29.6
161-124 R or L	1	43	109.2	27	78.7	41	104.1	43.1	75	34.1
161-136 R or L	1	55	139.7	27	78.7	41	104.1	53.6	85	38.6
162-118 R or L	2	53	134.6	27	78.7	41	104.1	51.9	80	36.4
162-124 R or L	2	59	149.9	27	78.7	41	104.1	56.3	90	40.9
162-136 R or L	2	71	180.3	27	78.7	41	104.1	67.7	100	45.5
163-118 R or L	3	69	175.3	27	78.7	41	104.1	65.9	100	45.5
163-124 R or L	3	75	190.5	27	78.7	41	104.1	71.2	110	50.0
163-136 R or L	3	87	221.0	27	78.7	41	104.1	81.7	120	54.6
164-118 R or L	4	85	215.9	27	78.7	41	104.1	80.0	120	54.6
164-124 R or L	4	91	231.1	27	78.7	41	104.1	85.3	130	59.1
164-136 R or L	4	103	261.6	27	78.7	41	104.1	95.8	140	63.6

DUKE MANUFACTURING CO.
 2305 N. Broadway
 St. Louis, MO 63102



800.735.3853 Toll Free
 800.231.1130 In Missouri
 314.231.5074 Fax
 www.dukemfg.com

Specification subject to change