



# Specifications

F.O.B St. Louis, Missouri 63102



**613Q-E1V**  
(Shown w/optional casters)

**OPTIONS:**

- Stainless steel interior
- 27" stainless steel angular legs
- Open leg base, stainless steel, w/rack guides
- Stainless steel back enclosure panel
- Seismic feet
- Field stacking kit
- High Voltage (380/415/440/480)
- Casters
- Porcelain drip tray
- Extra oven racks - standard and deep depth
- Prison package - tamper proof screws, lexan hinged cover with lockable clasp
- Extended warranty

**AGENCY LISTINGS:**



**DUKE MANUFACTURING CO.**  
2305 N. Broadway  
St. Louis, MO 63102

800.735.3853 Toll Free  
314-231-1130 In Missouri  
314.231.5074 Fax  
www.dukemfg.com

**Approval Stamp(s):**

**PRODUCT INFORMATION:**

PROJECT: \_\_\_\_\_  
ITEM: \_\_\_\_\_  
QUANTITY: \_\_\_\_\_

**MODEL:**

**Duke Convection Ovens - "Q" Series  
Single Section - Standard Depth - Electric**

- 613Q-E1** Single section, standard depth

**STANDARD FEATURES:**

- 6 racks/13 rack positions
- Porcelain interior finish
- 50/50 stainless steel doors
- Double pane glass both doors
- 27" angular painted legs

**OVEN SECTION:**

- Stainless steel front, sides and top
- 1-1/2" insulation on bottom, sides and back
- 3" insulation on top

**OVEN CONTROLS:**

- "V" - Basic snap action thermostat (200° - 500°F), 60 minute electric dial timer with continuous sound buzzer, 2-speed fan
- "XX" - Solid state digital time and temperature controls, 12-hour countdown timer, **Cook and Hold** feature, 2-speed fan, Pulse fan capability
- "ZZ" - 10 programmable menu buttons, 5-rack ID timers, computerized digital time and temperature controls, Cook and Hold feature, 2-speed fan, Pulse Fan capacity

**SHORT FORM SPECIFICATIONS:**

**Duke Convection Ovens - "Q" Series - Electric - Single Section - Standard Depth.** Unit shall have stainless steel exterior front, sides, door, top, interior door liners and door gaskets. Bottom, back and sides, to be fully insulated with 1-1/2" thick board type insulation, top to have 3" thick insulation. Interior shall be porcelain enameled interior, with 6 racks and 13 rack positions and 7/8" radius coved corners. Each oven section shall be heated with 11 KW input, with 1/2 HP, 2-speed blower motor. Fuse protected against overload. An ON-OFF-COOL DOWN switch shall be supplied. Doors shall be 50/50 independently opening, stainless steel with doublepane glass in both doors mounted on full length solid stainless steel shafts and bronze bushings for each door. Interior lighting to be (2) 50 watt, 115v bulbs. Legs shall be angular 27" high painted, with adjustable feet. Overall dimensions of unit shall be: 60" height, including 27" legs, 38" width, depth of 39-1/2" and cavity dimensions of 29"W x 24"H x 24"D.

**DUKE CONVECTION OVENS  
"Q" SERIES - ELECTRIC - STANDARD DEPTH**

□ **613Q-E1** Single section, standard depth

Electrical Specifications - Per Section				
	208V Amps	240V Amps	480V Amps	KW
1 Phase	52.8	45.8	n/a	10.0
3 Phase	30.5	26.5	13.3	10.0

▲ - Electronic connection point

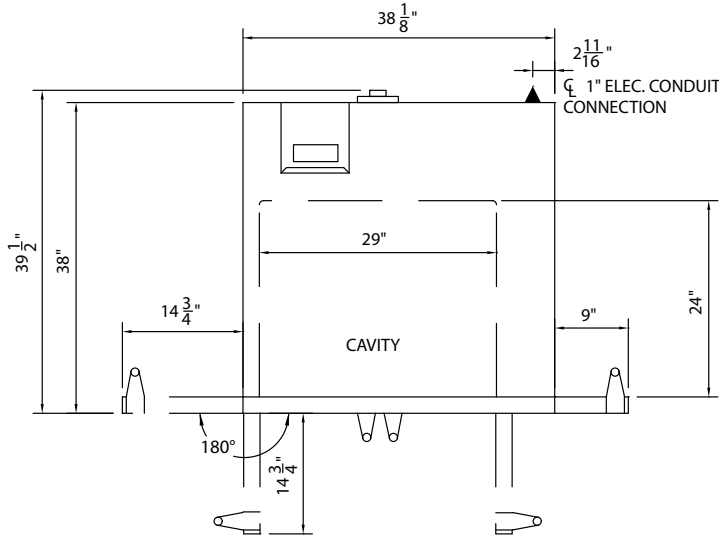

**TOP VIEW**

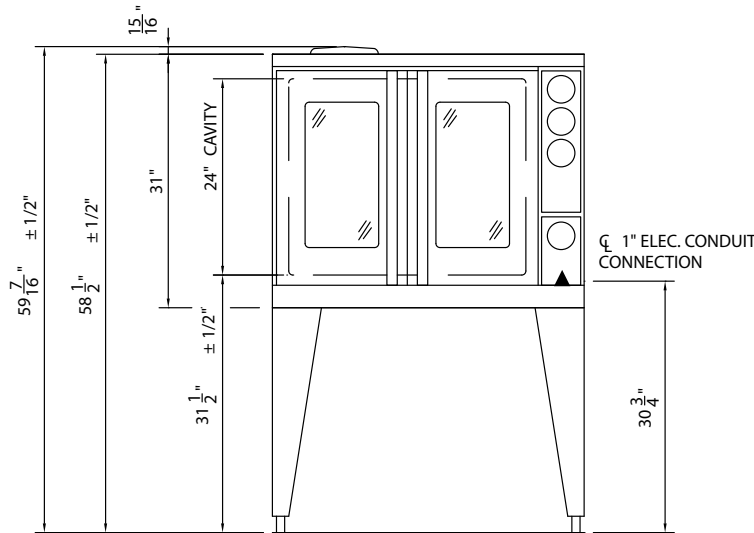

**FRONT VIEW**

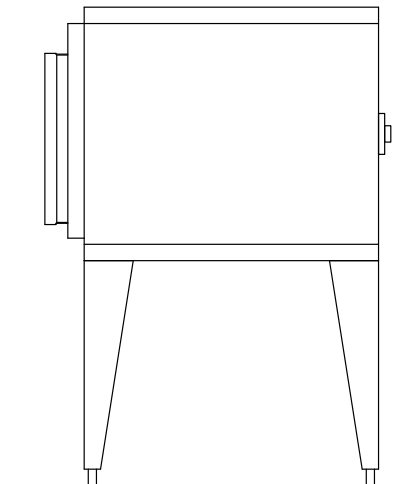

**RIGHT SIDE VIEW**

DIMENSIONS:

FREIGHT CLASS: 85

Model	Depth front view		Width		Height top view		Cube ft. crated	Weight	
	in	cm	in.	cm	in.	cm		lbs	kg
613Q-E1	39-1/2	100.3	38	96.5	60	152.4	59.6	505	230.0



**DUKE MANUFACTURING CO.**  
2305 N. Broadway  
St. Louis, MO 63102

800.735.3853 Toll Free  
800.231.1130 In Missouri  
314.231.5074 Fax  
www.dukemfg.com

Specification subject to change

01/10  
Printed in U.S.A  
© 2010, Duke Manufacturing Co.