

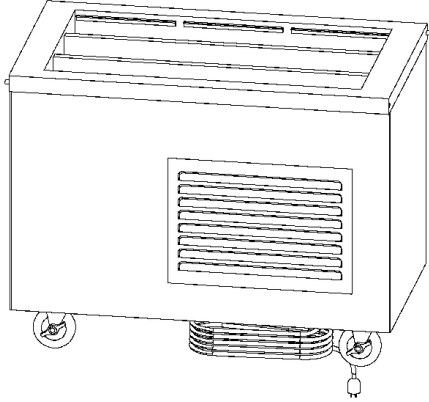

# Specifications

F.O.B Sedalia, Missouri 65301



### OPTIONS:

- 8' or 10' cord and plug in lieu of standard 6'
- 1-color laminate on body/second color
- laminate on tray slide - **HBMODA1**
- Laminate finish other than standard eight (8) finishes - **HBMODA2**
- Designer Food Shields - **TS Series**
- Glass display shelves - **98x Series**
- Buffet shelves - **83x, 93x Series**
- Serving shelves - **956-x, 956-460 - x Series**
- Louvered Kickplates - (stainless)/(painted)/(laminate to match body)
- 2-color tray slide - **HBMOD12**
- Heritage laminated trayslides
- End shelf
- Solid trayslides
- 3-bar trayslides
- Bread and cheese board - **HBMODJ1**
- Internal locking device
- Legs in lieu of casters

### AGENCY LISTING:



**DUKE MANUFACTURING CO.**  
**2305 N. Broadway**  
**St. Louis, MO 63102**

**800.735.3853 Toll Free**  
**314.231.5074 Fax**  
**www.dukemfg.com**

### Approval Stamp(s):

### PRODUCT INFORMATION:

PROJECT: \_\_\_\_\_  
 ITEM: \_\_\_\_\_  
 QUANTITY: \_\_\_\_\_

### MODEL:

### Heritage™ Buffet - Cold Pan Tri-Channel - Meets NSF Standard 7

- HB-2M-TC** 32" length unit
- HB-3M-TC** 46" length unit
- HB-4M-TC** 60" length unit
- HB-5M-TC** 74" length unit
- HB-6M-TC** 88" length unit

### TOP:

- Heavy gauge, 300 Series stainless steel
- Flanged down 2" on all four sides
- Formed down into heavy gauge stainless steel cold pan

### BODY:

- Heavy gauge paint grip steel
- Laminate patterns:
  - Beige Grafix - **HB-01**
  - Oxide - **HB-04**
  - Fallen Leaves - **HB-07**
  - Chestnut Burl - **HB-11**
  - Stellar - **HB-03**
  - Northern Oak - **HB-06**
  - Tortoise Lacquer - **HB-08**
  - Amber Maple - **HB-12**
- Stainless steel trim strips on corners
- Flanged and channeled edges for strength
- Welded together with reinforcements
- Stainless steel removable grille
- Mounted on NSF listed 5" diameter swivel casters, two with locks, all non-marking polyurethane tires
- 6' electric cord and plug

### TRI CHANNEL COOLED COLD PAN

- 20 gauge, 300 Series stainless steel liner
- Insulated on all sides and bottom
- Refrigerated coils, controls and compressor compartment - R404A

### SHORT FORM SPECIFICATIONS:

**Duke Heritage™ Buffet - Cold Pan - Tri-Channel - Meets NSF Standard 7.** Top shall be constructed of 16 gauge, 300 Series stainless steel, with edges turned down 2" straight. Body of units shall be heavy gauge paint grip steel with eight (8) optional laminate patterns. Stainless steel trim strips on corners of body panels. Unit provided with a 3 rail Tri-Channel NSF Standard 7 pan designed to hold 1/3rd, 1/6th and 1/9th size pans without the use of adaptor bars. Standards include; polyurethane casters, pull out compressor slides, on/off switch, 6'-0" electric cord and plug and 5-Year compressor motor warranty.

# HERITAGE<sup>®</sup> FROM DUKE

## HERITAGE™ BUFFET - COLD PANS TRI-CHANNEL MEETS NSF STANDARD 7

- HB-2M-TC                    32" length unit
- HB-3M-TC                    46" length unit
- HB-4M-TC                    60" length unit
- HB-5M-TC                    74" length unit
- HB-6M-TC                    88" length unit

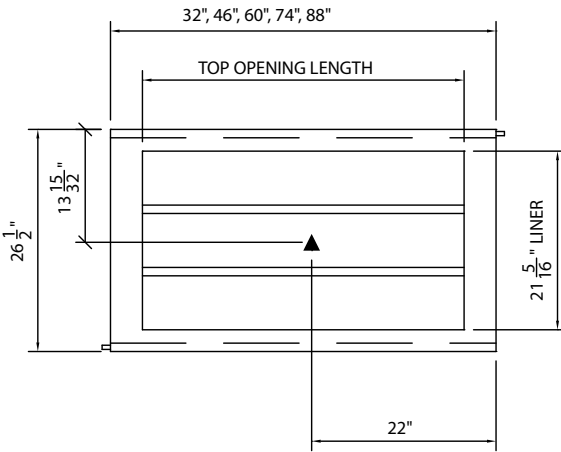

**TOP VIEW**

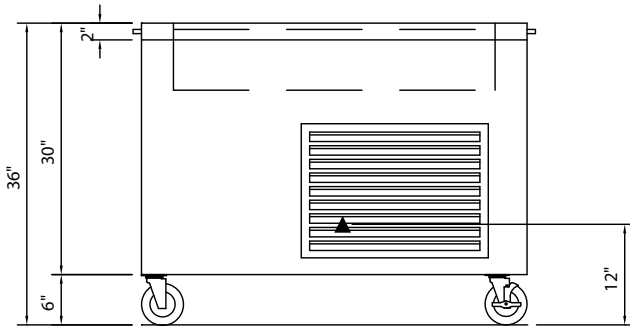

**FRONT VIEW**

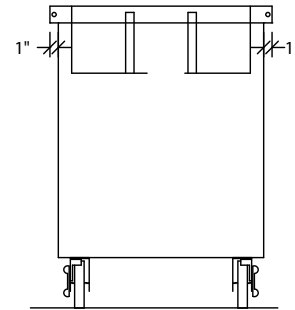

**RIGHT SIDE VIEW**

DESCRIPTION:

FREIGHT CLASS: 150

Model	Overall Length	Overall Width	Tri-Channel Top Cutout Dimensions			Cubic Ft. Crated	Weight		120/1 NEMA #5-15P	
			Length	Width	Depth		Lbs.	Kg.	Amps	HP
HB-2M-TC	32"	26 1/2"	25 5/8"	21 5/16"	8"	26.3	320	145	5.5	1/4
HB-3M-TC	46"	26 1/2"	38 3/8"	21 5/16"	8"	36.0	460	209	6.7	1/3
HB-4M-TC	60"	26 1/2"	51 1/8"	21 5/16"	8"	45.7	606	272	6.7	1/3
HB-5M-TC	74"	26 1/2"	63 7/8"	21 5/16"	8"	56.8	740	336	6.5	0.4
HB-6M-TC	88"	26 1/2"	76 5/8"	21 5/16"	8"	68.6	860	399	6.5	0.4



**DUKE MANUFACTURING CO.**  
2305 N. Broadway  
St. Louis, MO 63102

800.735.3853 Toll Free  
800.231.1130 In Missouri  
314.231.5074 Fax  
[www.dukemfg.com](http://www.dukemfg.com)

Specification subject to change