



Specifications

F.O.B Sedalia, Missouri 65301



HB3-1H2C

OPTIONS:

- 8" deep liner in lieu of 5"
- Internal locking device
- 220v - 50 Hz compressor
- Condensate evaporator - **COND-EVAP**
- Three phase wiring
- 8' or 10' cord and plug in lieu of 6'
- 1-color laminate on body/second color laminate on tray slide - **HBMODA1**
- Laminate finish other than standard eight (8) finishes - **HBMODA2**
- Designer food shields (**TS Series**)
- Glass display shelves (**98x Series**)
- Buffet shelves (**83x, 93x Series**)
- Serving shelves (**956-x, 956-460 - x Series**)
- Lights in canopy - **HB-50**
- Heat/lights in canopy - **HB-60**
- Kickplates - **HBMODH1** (stainless) / **HBMODH2** (painted) / **HBMODH3** (laminiate to match body)
- Heritage laminated trayslides
- End shelf
- Solid trayslides
- 3-bar trayslides
- Bread and cheese board - **HBMODJ1**
- False bottom for cold pan - **FB**
- Legs in lieu of casters

AGENCY LISTING:



DUKE MANUFACTURING CO.
2305 N. Broadway
St. Louis, MO 63102

800.735.3853 Toll Free
314.231.5074 Fax
www.dukemfg.com

Approval Stamp(s):

PRODUCT INFORMATION:

PROJECT: _____

ITEM: _____

QUANTITY: _____

MODEL:

Heritage Buffet - Hot/Cold Cold Pan - 5" Deep

- | | |
|---|---|
| <input type="checkbox"/> HB3-2H1C 2 hot/1 cold | <input type="checkbox"/> HB4-1H3C 1 hot/3 cold |
| <input type="checkbox"/> HB3-1H2C 1 hot/2 cold | <input type="checkbox"/> HB4-3H1C 3 hot/1 cold |
| <input type="checkbox"/> HB5-3H2C 3 hot/2 cold | <input type="checkbox"/> HB4-2H2C 2 hot/2 cold |
| <input type="checkbox"/> HB5-2H3C 2 hot/3 cold | <input type="checkbox"/> HB5-1H4C 1 hot/4 cold |

TOP:

- 16 gauge, 300 Series stainless steel
- Flanged down 2" on all four (4) sides
- Independently operated hot food wells
- Single control mechanically cooled ice pan sections

BODY:

- Heavy gauge paint grip steel
- Laminate patters:

□ Beige Grafix - HB-01	□ Stellar - HB-03
□ Oxide - HB-04	□ Northern Oak - HB-06
□ Fallen Leaves - HB-07	□ Azul Granite - HB-13
□ Chestnut Burl - HB-11	□ Amber Maple - HB-12
- Stainless steel trim strips on corners
- Flanged and channeled edges for strength
- Welded together with reinforcements
- Mounted on NSF listed 5" diameter swivel casters, two with locks, all non-marking polyurethane tires

HOT FOOD SECTION:

- Stainless steel liners, 12" x 20", insulated with fiberglass
- Each section to have 500 or 750 watt electric exposed element
- Individual infinite controls
- 6' cord and plug
- Spillage pans included, aluminum

MECHANICALLY ASSISTED ICE PAN SECTION:

- 18 gauge, 300 Series stainless steel liner
- 12-1/16" x 20-1/16" die stamped openings - 5" deep
- Insulated on all four sides and bottom
- 1" cast brass drain and plug
- Refrigerant coils, controls and compressor compartment - R134A

SHORT FORM SPECIFICATIONS:

Duke Heritage Buffet - Hot/Cold - 5" Deep Cold Pan. Top shall be 16 gauge 300 Series stainless steel with top flanged down 2" on all four sides. Top shall have die-stamped openings measuring 12" x 20" for hot and cold sections. Heavy gauge stainless steel liners for all openings. Cold pan to have 1" cast brass drain and plug and equipped with refrigerant coils, controls and compressor compartment with removable grille. Cold pan liner 5" deep. Hot food sections to have individual elements (500 or 750 watt), fitted inside warming compartments controlled by infinite switches. Hot food operation on operator's left. 576 spillage pans provided. 6' cord and plug provided. Body of units shall be heavy gauge paint grip steel with option of eight (8) laminate patterns. Stainless steel trim strips on corners of body panels. NSF listed casters with 5" dia. polyurethan swivel type wheels are included.

HBU-02

HERITAGE[®] FROM DUKE

Heritage Buffet - Hot/Cold Cold Pan - 5" Deep

- HB3-2H1C 2 hot/1 cold
- HB3-1H2C 1 hot/2 cold
- HB5-3H2C 3 hot/2 cold
- HB5-2H3C 2 hot/3 cold
- HB4-1H3C 1 hot/3 cold
- HB4-3H1C 3 hot/1 cold
- HB4-2H2C 2 hot/2 cold
- HB5-1H4C 1 hot/4 cold

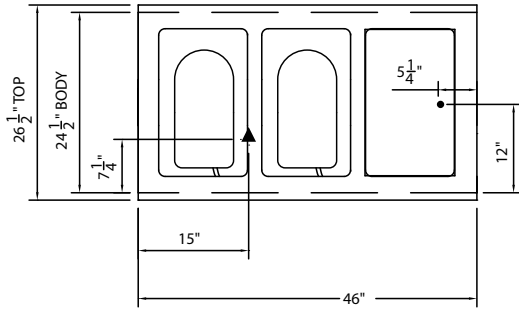

TOP VIEW

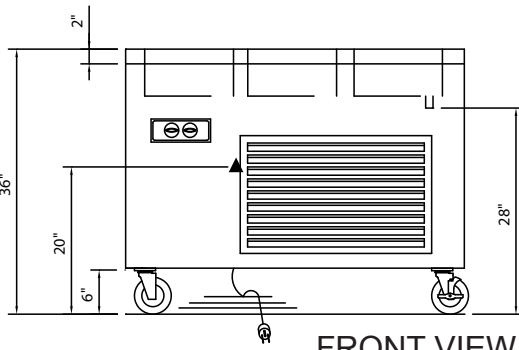

FRONT VIEW

LEGEND	
▲	- ELECTRICAL CONNECTION
●	- DRAIN LOCATION

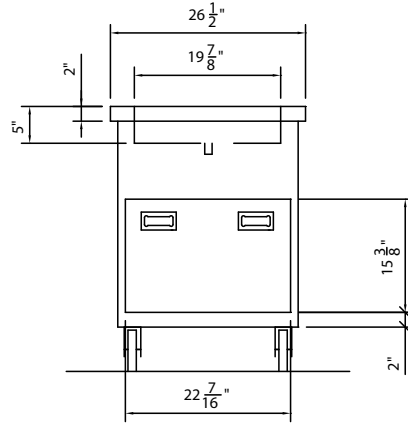

RIGHT SIDE VIEW

DIMENSIONS:

All Units 26-1/2 (67.3 cm) Wide & 36" (91.4 cm Tall)

FREIGHT CLASS: 150

Model	Length		Cube ft. crated	Weight		Model	Length		Cube ft. crated	Weight	
	in.	cm		lbs.	kg		in.	cm		lbs.	kg
HB3-2H1C	46	116.8	36.0	432	196.4	HB4-1H3C	60	152.4	45.7	570	259.1
HB3-1H2C	46	116.8	36.0	432	196.4	HB5-3H2C	74	188.0	55.4	745	338.6
HB4-2H2C	60	152.4	45.7	570	259.1	HB5-2H3C	74	188.0	55.4	745	338.6
HB4-3H1C	60	152.4	45.7	570	259.1	HB5-1H4C	74	188.0	55.4	745	338.6

ELECTRICAL SPECIFICATIONS:

Model	HP	120 volt - 500 watt elements			120/208 volt - 750 watt elements			120/240 volt - 750 watt elements		
		watts	amps	NEMA	watts	amps	NEMA	watts	amps	NEMA
HB3-2H1C	1/5	1600	13.3	5-15	2100	10.1	L14-30	2100	8.8	L14-30
HB3-1H2C	1/5	1100	9.2	5-15	1350	6.3	L14-30	1350	5.8	L14-30
HB4-2H2C	1/5	1600	13.3	5-15	2100	9.9	L14-30	2100	9.0	L14-30
HB4-3H1C	1/5	2100	17.5	L5-30	2850	13.5	L14-30	2850	12.1	L14-30
HB4-1H3C	1/5	1100	9.2	5-15	1350	6.3	L14-30	1350	5.8	L14-30
HB5-3H2C	1/5	2150	17.5	L5-30	2900	13.5	L14-30	2900	12.1	L14-30
HB5-2H3C	1/5	1650	13.4	5-15	2150	9.9	L14-30	2150	9.0	L14-30
HB5-1H4C	1/4	1280	10.7	5-15	1530	9.6	L14-30	1530	9.1	L14-30

DUKE MANUFACTURING CO.

2305 N. Broadway
St. Louis, MO 63102

800.735.3853 Toll Free
800.231.1130 In Missouri
314.231.5074 Fax
www.dukemfg.com

