



Specifications

F.O.B Sedalia, Missouri 65301



HB2HF

OPTIONS:

- Three phase wiring - not available with 120v
- Internal locking device
- Heritage laminated trayslides
- 1-color laminate on body/second color laminate on tray slide
- HBMODA1**
- Laminate finish other than standard eight (8) finishes -
- HBMODA2**
- Designer food shields - **TS Series**
- Glass display shelves - **98x Series**
- Buffet shelves - **83x, 93x Series**
- Serving shelves - **956-x, 956-460-x Series**
- Lights in canopy - **HB-50**
- Heat/lights in canopy - **HB-60**
- Kickplates - **HBMODH1** (stainless)/ **HBMODH2** (painted) /**HBMODH3** (laminate to match body)
- Solid trayslides
- 3-bar trayslides
- Bread and cheese board - **HBMODJ1**
- End Shelf
- Legs in lieu of casters

AGENCY LISTING:



DUKE MANUFACTURING CO.
2305 N. Broadway
St. Louis, MO 63102

800.735.3853 Toll Free
314.231.5074 Fax
www.dukemfg.com

Approval Stamp(s):

PRODUCT INFORMATION:

PROJECT: _____
 ITEM: _____
 QUANTITY: _____

MODEL:

Heritage Buffet - Hot Food - Electric

- HB2HF** 32" length unit w/(2) heat wells
- HB3HF** 46" length unit w/(3) heat wells
- HB4HF** 60" length unit w/(4) heat wells
- HB5HF** 74" length unit w/(5) heat wells

TOP:

- 16 gauge, 300 Series stainless steel
- Flanged down 2" on all four (4) sides
- Die-stamped beaded openings - 12" x 20"

BODY:

- Heavy gauge paint grip steel
- Laminate patters:
 - Beige Grafix - **HB-01**
 - Oxide - **HB-04**
 - Fallen Leaves - **HB-07**
 - Chestnut Burl - **HB-11**
 - Stellar - **HB-03**
 - Northern Oak - **HB-06**
 - Azul Granite - **HB-13**
 - Amber Maple - **HB-12**
- Stainless steel trim strips on corners
- Flanged and channeled edges for strength
- Welded together with reinforcements
- Removable access panel on one end
- mounted on NSF listed 5" diameter swivel casters, two with locks, all non-marking polyurethane tires

HOT FOOD SECTION

- Stainless steel sealed wells 12" x 20", insulated with fiberglass
- Each section to have electric elements under well
- Individual brass drains, copper manifolds and brass master valve
- Individual infinite controls
- 6' cord and plug

SHORT FORM SPECIFICATIONS:

Duke Heritage Buffet - Hot Food - Electric. Top shall be constructed of 16 gauge, 300 Series stainless steel, with edges flanged down 2" on all four sides and die-stamped openings with raised beaded edges, measuring 12" x 20". Heat compartments shall have stainless steel liners (sealed wells) and be fully insulated with fiberglass. Each section to have element under warming compartment and individually controlled by infinite switch. Each well to have 1/2" drain fitted with copper tube manifolds and brass master valve located behind removable access panel on one end. 6' cord and plug. Body of units shall be heavy gauge paint grip steel with option of eight (8) laminated patterns. Stainless steel trim strips on corners of body panels. NSF listed casters, 5" diameter, polyurethane, swivel-type, two with locks, all non-marking tires, shall be furnished

HERITAGE[®]

FROM DUKE

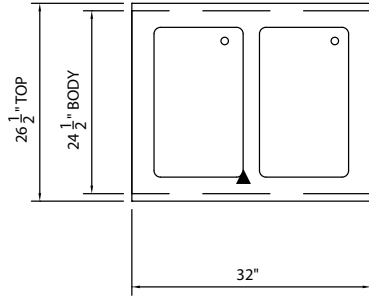

TOP VIEW

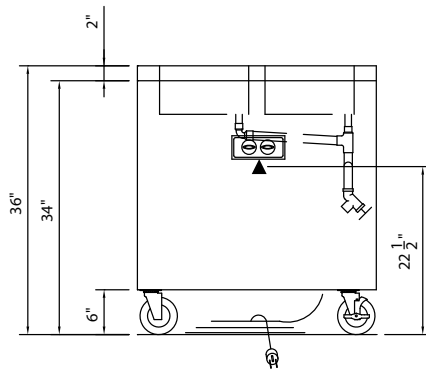

FRONT VIEW

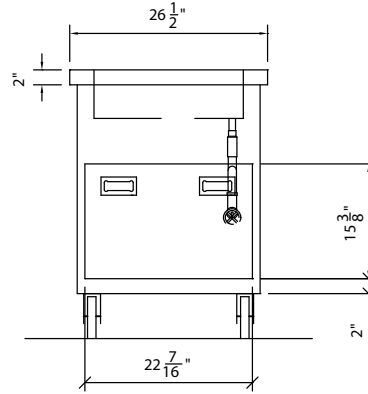

RIGHT SIDE VIEW

Heritage Buffet - Hot Food - Electric

- HB2HF 32" length unit
- HB3HF 46" length unit
- HB4HF 60" length unit
- HB5HF 74" length unit

LEGEND	
▲	ELECTRICAL CONNECTION

DIMENSIONS:

FREIGHT CLASS: 100

	Length		Width		Height		Cube ft crated	Weight	
	in.	cm.	in.	cm.	in.	cm.		lbs	kg
HB2HF	32	81.3	26-1/2	67.3	36	91.4	26.3	265	120.5
HB3HF	46	116.8	26-1/2	67.3	36	91.4	36.0	395	180.0
HB4HF	60	152.4	26-1/2	67.3	36	91.4	45.7	525	238.6
HB5HF	74	188.0	26-1/2	67.31	36	91.4	55.4	655	297.7

ELECTRICAL SPECIFICATIONS:

Model	120 Volt - 750 watt elements			208 Volt - 750 watt elements			240 Volt - 750 watt elements		
	watts	amps	NEMA	watts	amps	NEMA	watts	amps	NEMA
HB2HF	1500	12.5	5-15	1500	7.2	6-20	1500	6.3	6-20
HB3HF	2250	18.8	L5-30	2250	10.8	6-20	2250	9.4	6-20
HB4HF	3000	25.0	5-50	3000	14.4	6-20	3000	12.5	6-20
HB5HF	3750	31.3	5-50	3750	18.0	L6-30	3750	15.6	6-20

DUKE MANUFACTURING CO.

2305 N. Broadway
St. Louis, MO 63102

800.735.3853 Toll Free
800.231.1130 In Missouri
314.231.5074 Fax
www.dukemfg.com

