

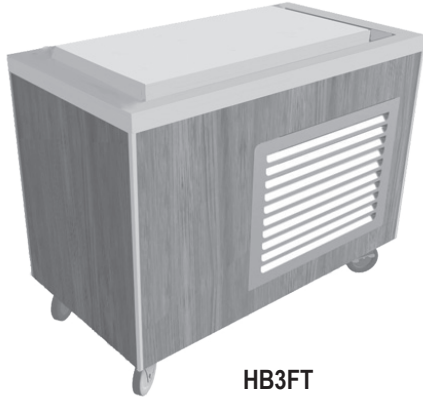

Specifications

F.O.B Sedalia, Missouri 65301



HB3FT

OPTIONS:

- 220v - 50 Hz compressor
- Internal locking device
- Condensate evaporator - **COND EVAP**
- Heritage laminated trayslides
- 1-color laminate on body/second color laminate on tray slide - **HBMODA1**
- Laminate finish other than standard eight (8) finishes - **HBMODA2**
- Designer sneeze guards (**TS Series**)
- Glass display shelves (**98x Series**)
- Buffet shelves (**83x, 93x Series**)
- Serving shelves (**956-x, 956-460 - x Series**)
- Lights in canopy - HB-50
- Kickplates - **HBMODH1** (stainless) / **HBMODH2** (painted)/ **HBMODH3** (laminate to match body)
- End shelf
- Solid trayslides
- 3-bar trayslides
- Bread and cheese board - **HBMODJ1**
- Legs in lieu of casters

AGENCY LISTING:



DUKE MANUFACTURING CO.
2305 N. Broadway
St. Louis, MO 63102

800.735.3853 Toll Free
314.231.5074 Fax
www.dukemfg.com

Approval Stamp(s):

PRODUCT INFORMATION:

PROJECT: _____
 ITEM: _____
 QUANTITY: _____

MODEL:

Heritage Buffet Frost Top

- HB3FT** 46" length unit/36-1/4" x 17-1/4" display
- HB4FT** 60" length unit/50-1/4" x 17-1/4" display
- HB5FT** 74" length unit/64-1/4" x 17-1/4" display

TOP:

- 16 gauge, 300 Series stainless steel rim and display
- Flanged down 2" on all four sides
- Display raised 1" above body
- Drain gutter on all four sides
- 1" drain and plug
- Compressor of 1/4HP operates on 120v
- Refrigerated coils under top - R134A

BODY:

- Heavy gauge paint grip steel
- Laminate patterns:
 - Beige Grafix - **HB-01**
 - Oxide - **HB-04**
 - Fallen Leaves - **HB-07**
 - Chestnut Burl - **HB-11**
 - Stellar - **HB-03**
 - Northern Oak - **HB-06**
 - Azul Granite - **HB-13**
 - Amber Maple - **HB-12**
- Stainless steel trim strips on corners
- Flanged and channeled edges for strength
- Welded together with reinforcements
- Stainless steel removable grille
- Mounted on NSF listed 5" diameter swivel casters, two with locks, all non-marking polyurethane tires
- 6' electric cord and plug

SHORT FORM SPECIFICATIONS:

Duke Heritage Buffet - Frost Top. Units to have 16 gauge stainless steel top raised 1" above unit with drain gutter on all four sides, with edges flanged down 2" on all four sides. Compressor (1/4 HP, 120V, 5-15 NEMA) furnished. Body of units shall be heavy gauge paint grip steel with option of eight (8) laminate patterns. Stainless steel trim strips on corners of body panels. Must choose finish for body at time of order. NSF listed casters, 5" diameter, polyurethane, swivel-type, two with locks, all non-marking tires, shall be furnished.

HERITAGE[®] FROM DUKE

HERITAGE BUFFET

Frost Top

- **HB3FT** 46" length unit/36-1/4" X 17-1/8" display
- **HB4FT** 60" length unit/50-1/4" x 17-1/8" display
- **HB5FT** 74" length unit/64-1/4" x 17-1/8" display

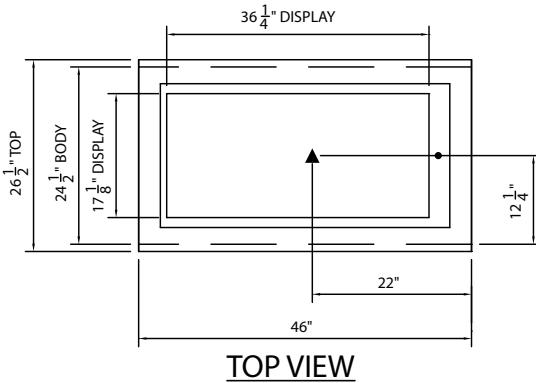

LEGEND	
▲	ELECTRICAL CONNECTION
●	DRAIN LOCATION

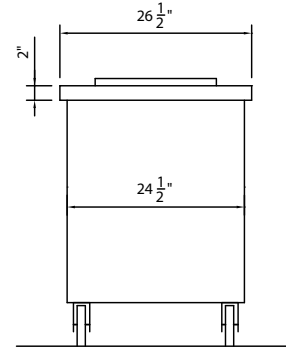
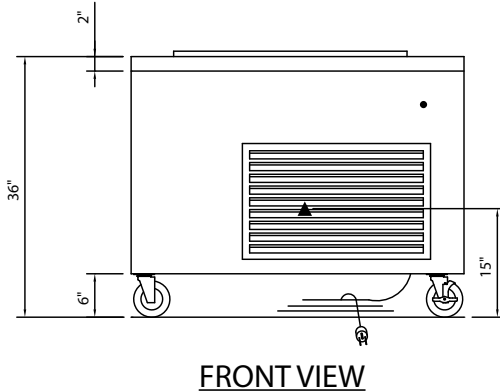

DIMENSIONS:

FREIGHT CLASS: 150

Model	Length		Width		Height		Display Surface in.	Cube ft. crated	Weight	
	in.	cm	in.	cm	in.	cm			lbs	kg
HB3FT	46	116.8	26-1/2	67.3	36	91.4	36-1/4 X 17-1/8	36.0	460	209.1
HB4FT	60	152.4	26-1/2	67.3	36	91.4	50-1/4 X 17-1/8	45.7	670	304.6
HB5FT	74	188.0	26-1/2	67.3	36	91.4	64-1/4 X 17-1/8	55.4	760	345.5

ELECTRICAL SPECIFICATIONS:

Model	HP	120 volt w/no lights	
		amps	NEMA
HB3FT	1/4	6.0	5-15
HB4FT	1/4	6.0	5-15
HB5FT	1/4	6.0	5-15

DUKE MANUFACTURING CO.

2305 N. Broadway
St. Louis, MO 63102

800.735.3853 Toll Free
800.231.1130 In Missouri
314.231.5074 Fax
www.dukemfg.com



"Your Solutions Partner"

Specification subject to change