



# Specifications

F.O.B Sedalia, Missouri 65301

Approval Stamp(s):

**PRODUCT INFORMATION:**

PROJECT: \_\_\_\_\_

ITEM: \_\_\_\_\_

QUANTITY: \_\_\_\_\_

AEROHOT DISHTABLES - MODIFICATIONS

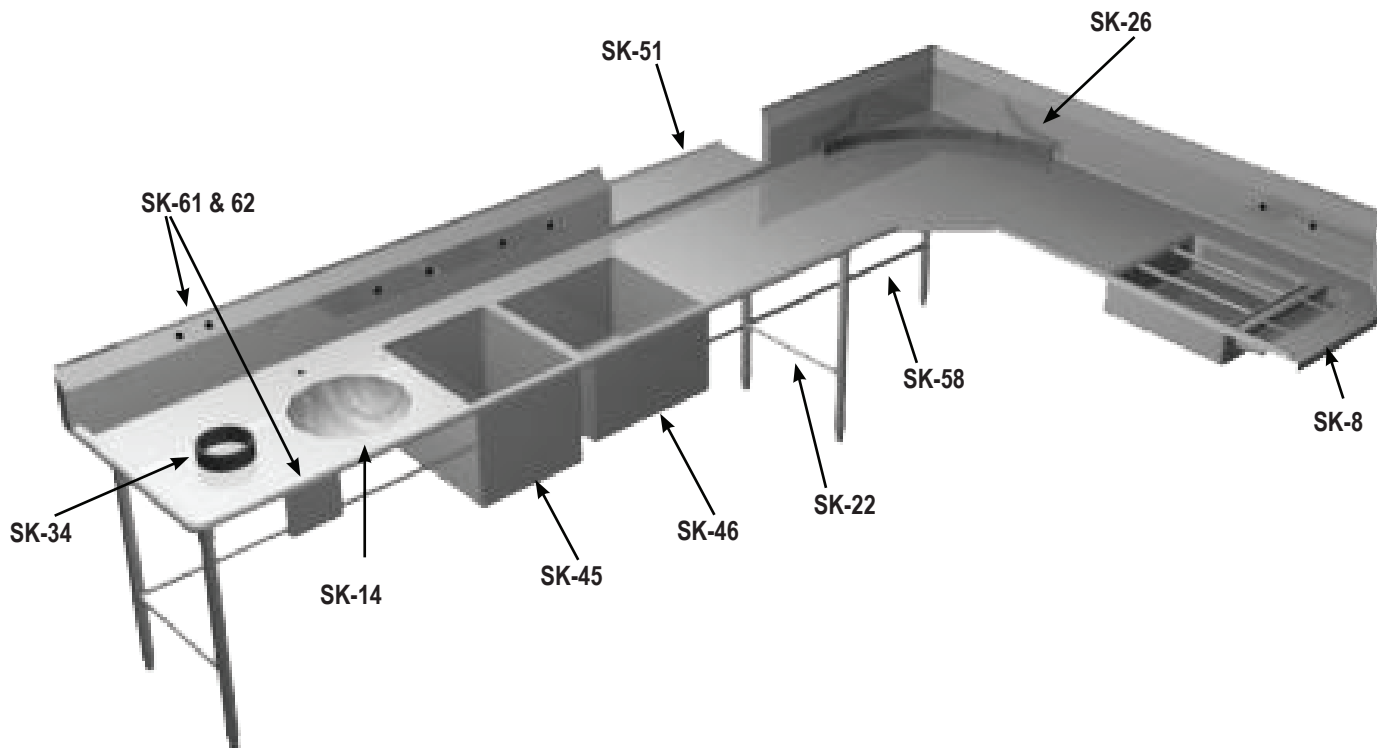

SEE BACK PAGE FOR MODIFICATIONS DETAILS

Catalog No. DISHMODS

DUKE MANUFACTURING CO.  
2305 N. Broadway  
St. Louis, MO 63102

800.735.3853 Toll Free  
314.231.1130 In Missouri  
314.231.5074 Fax  
www.dukemfg.com

A.I.A. File No. 35-C-13

# Aerohot®

## DUKE DISHTABLES MODIFICATIONS

- Provisions for sink mounted pot rack and /or shelf - **SK-1**
- Stainless steel pot racks, 2-bar, riser mounted - **SK-2**
- Stainless steel 12" wide shelf, riser mounted - **SK-3**
- Poly board sink cover - **SK-4**
- Carving board, 3/4" H.D. Ploy - **SK-5**
- Z Bracket for wall attachments - **SK-7**
- Waste Trough furnished w/2" deep removable basket - **SK-8**
- High backsplash - **SK-9**
- Extra drainboard length - **SK-10**
- Stainless steel sink cover - **SK-13**
- Installation of disposal cone - **SK-14**
- Installation of disposer collar - **SK-15**
- Special faucet hold location - **SK-16**
- Working height revisions - **SK-17**
- Stainless steel undershelf - **SK-18**
- Flanged bullet feet - **SK-19**
- Provision for pot washer - **SK-20**
- Provision for Hatco Heater - **SK-21**
- Stainless steel welded leg assembly (H-frame) - **SK-22**
- Stainless steel apron to cover welded bowls - **SK-23**
- Special size sink bowl (special depth) - **SK-24**
- Curve rack bar guides - **SK-26**
- Install booster heater brackets (brackets not included) - **SK-27**
- Salvajor troughveyor modification - **SK-28**
- Column cut-out - **SK-30**
- Splash cut-out - **SK-31**
- Scrap block installed - **SK-34**
- Modified prerinse sink position - **SK-37**
- Incremental length on 60" side of corner table - **SK-41**
- 16" x 21" x 14" fully fabricated welded bowls welded into top of 1, 2, or 3 compartments - **SK-45**
- 20" x 20" x 14" fully fabricated welded bowls welded into top of 1, 2, or 3 compartments - **SK-46**
- End splash - **SK-49**
- Scrap trough - **SK-50**
- Pass-thru (please not wall dimension) - **SK-51**
- Drainboard corner turn - **SK-54**
- Stainless steel perforated basket with molded slide rail - **SK-57**
- Longitudinal crossrail - **SK-58**
- Rack slide - **SK-59**
- Vacuum breaker holes - **SK-61**
- Small switch bracket - **SK-62**
- Large control bracket - **SK-63**



Perforated Basket - **SK-57**

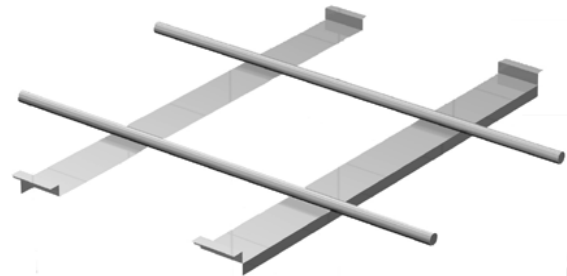

Rack Slide - **SK-59**



**DUKE MANUFACTURING CO.**  
2305 N. Broadway  
St. Louis, MO 63102

800.735.3853 Toll Free  
800.231.1130 In Missouri  
314.231.5074 Fax  
[www.dukemfg.com](http://www.dukemfg.com)

Specification subject to change

01/10  
Printed in U.S.A  
© 2010, Duke Manufacturing Co.