

PROCESSING

Berkel**C32**
CONTINUOUS FEED FOOD PROCESSOR

Model C32

**FEATURES**

Berkel Model C32 continuous feed food processor is a high-performance machine that quickly and conveniently, slices, dices, shreds, grates, and juliennes vegetables, fruits and cheese. The C32 should not be used to dice or cube cheese or meat. Constructed of heavy-duty aluminum with integrated handles, the compact C32 is easy to move from one location to another. The continuous feed attachment includes an automatic start/stop function, feed tube and design that allows the operator to load product with both hands for the fastest possible processing. The dual interlock boosts operator protection. The C32 has a variety of cutting plates to optimize the versatility and productivity of this superior machine.

- C32** Continuous Feed Food Processor

STANDARD FEATURES

- Slices, dices, shreds, grates and juliennes fruit, vegetables, dry bread, cheese, nuts, etc.
- The C32 should not be used to dice or cube cheese or meat.
- Prepares up to 4.4 lbs (2 kg) per minute.
- 2-speed, 1½ HP, thermal motor protection with automatic reset.
- Furnished in 120/60/1, UL listed.
- Optimal speed settings and perfect cutting results for the required applications.
- Includes feed head and ejector plate.
- Only Model C32/2 is furnished with a 5/64" (2 mm) shredder plate and 5/32" (4 mm) slicing plate.
- Aluminum machine base and polycarbonate feed assembly for increased durability.

OPTIONS

- Model C32 is not furnished with cutting plates. Cutting plates with this model must be ordered separately. Unit without slicing and shredding plates.

ACCESSORIES (Packaged & Sold Separately)

- Slicing Plates – 1/32" (1 mm), 1/16" (1.5 mm), 5/64" (2 mm), 5/32" (4 mm), 1/4" (6 mm), 5/16" (8 mm), 3/8" (10 mm), 15/32" (12 mm) and 5/8" (15 mm)
- Crimping Plate – 3/16" (4.5 mm) and 5/16" (8 mm)
- Shredder Plates – 1/16" (1.5 mm), 5/64" (2 mm), 1/8" (3 mm), 3/16" (4.5 mm), 1/4" (6 mm) and 5/16" (8 mm)
- Fine and Extra Fine Grater Plates
- Julienne Plate – 5/64" x 5/64" (2x2 mm), 3/16" x 3/16" (4.5x4.5 mm) and 3/8" x 3/8" (10x10 mm)
- Dicing Grid – 5/16" x 5/16" (8x8 mm), 3/8" x 3/8" (10x10 mm), 15/32" x 15/32" (12x12 mm) and 5/8" x 5/8" (15x15 mm)
- Replacement Blades - Slicing and Crimping
- Wall Rack
- Stainless Steel Cutter/Mixer Bowl Assembly
 - Converts the C32 continuous food processor to a cutter/mixer bowl processor

Berkel

a division of ITW Food Equipment Group LLC



C32
CONTINUOUS FEED FOOD PROCESSOR

SPECIFICATIONS

Motor: 1½ hp, 2-speed, thermal motor protection with automatic reset.

Electrical: Furnished in 120/60/1, 9 amps, UL Listed, 3-wire electrical cord and plug. Cord is 6' in length.

Finish/Construction: Machine base of aluminum. Continuous feed attachment and ejector plate of polycarbonate. Cutting plates of polycarbonate and aluminum. All blades of stainless steel.

Controls: Sealed dial controls with integrated pulse function.

Speeds: 2 speeds (500/800 rpm) for slicing, dicing, shredding and grating.

Operator Protection: Dual interlocks keep machine from operating unless attachment is in the proper position.

Capacity: 4.4 lbs./minute.

Warranty: Parts, labor and travel coverage for one year, exclusive of wear items.

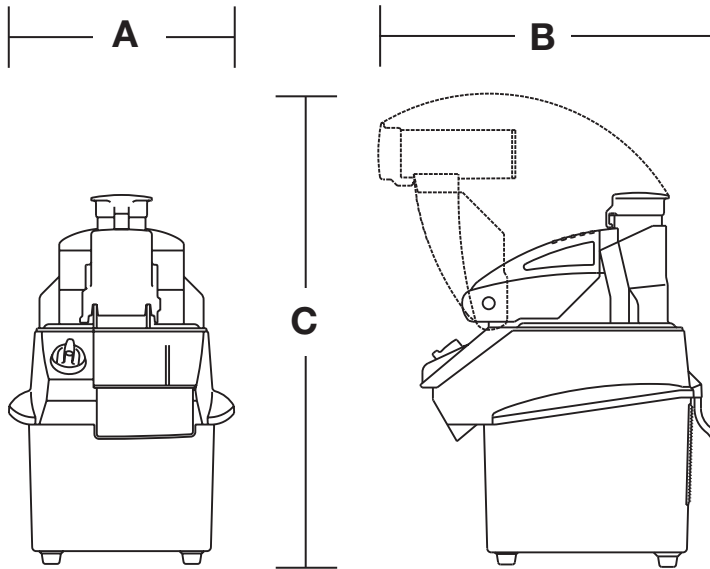

Continuous Feed

MODEL NO.	CAPACITY	PRODUCT DIMENSIONS			WEIGHT
		WIDTH A	DEPTH B	HEIGHT C	
C32	4.4 lbs./min (2 kg/min.)	11" (280 mm)	13¾" (350 mm)	23" (585 mm)	Net 23 lbs. (11 kg) Ship 33 lbs. (15 kg)

MOTOR	ELECTRICAL	CUTTING SPEEDS	BOX DIMENSIONS		
			WIDTH A	DEPTH B	HEIGHT C
1½ HP	120/60/1 9 amps	500/800 rpm	16¼" (413 mm)	16¼" (413 mm)	27" (686 mm)



P.O. Box 696 ■ Louisville, KY 40201 ■ Toll-free: 1-800-814-2028 ■ Local: 502-778-2791 ■ Quote & Order Fax: 1-800-444-0602